

Effect of High Performance Concrete Mixture on Behavior of Passive and Active Confined CFT

MORTEZA NAGHIPOUR, MARZIEH NEMATI, JAVAD JALALI

Civil Engineering Department

Babol Noshirvani University of Technology

Shariati Av., P. O. box : 484, Post Code : 47148 – 71167, Babol, Mazandaran

IRAN

m-naghi@nit.ac.ir

marziehnemati1362@gmail.com

javad.jalali@nit.ac.ir

MAHDI NEMATZADEH

Faculty of Engineering and Technology,

The University of Mazandran (UMZ),

Pasdaran Street, 57416-13534, P.O.Box: 416, Babolsar

IRAN

Mahdi Nematzadeh m.nematzadeh@umz.ac.ir

Abstract: Easy mixing and placement of concrete and ultimate performance of structural member regard to its cost is one of the important factor in concrete structures. This paper offers an innovative solution to enhance the workability of the core concrete of concrete filled steel tube (CFST) without using additives. This solution can be used for both passive and active CFTs. This study was performed in two phases. In the first phase, high performance concrete (HPC) mixture was introduced and compressive strength of this type of concrete was measured in order to investigate the efficiency of proposed mixture. In the second phase, the active and passive CFTs, with both conventional concrete (CC) and HPC mixtures were built and their flexural behavior was studied. The flexural capacity, energy absorption, flexibility and failure mode of the confined specimens as well as cracking pattern of the concrete core at the failure point are evaluated in this study. Obtained results showed the effectiveness of proposed method for concrete mixture design. HPC mixture not only increased the moment capacity and amount of absorbed energy of specimens but also changed the behavior of specimens. Moreover, this proposed HPC mixture was more effective for low compressive strength of the concrete core.

Key-Words: High performance concrete mixture, Fresh concrete, Active confinement, Passive confinement, flexural behaviour

1 Introduction

The use of concrete filled steel tubes (CFST) in the construction industry continues to increase, and methods for the design of such elements are continually being developed. Only a limited number of researches have focused on the behaviour of CFTs as beams [1]. In their research, the beam is defined as a structural member without axial loads. Such a member is typically used as a simple supported flexural component. Analysing flexural capacity, the presence of the concrete modifies the flexural behaviour of the composite member, because not only it contributes to the compression resistance, but also the local buckling of the steel tube in compression is delayed because of laterally

supported by the concrete [2]. In the past, the flexural behaviour of concrete filled steel tubes (CFST) has been performed by several researchers, such as Elchalakani *et. al.* [3], Furlong [4], Lu and Kennedy [1], Prion and Boehme [5], Tomii and Sakino [6], Uy B [7] and etc. the literature has been generally reviewed by Han [8]. A practical application of the CFT as a pure flexural member had been attempted in Japan for the construction of a bridge. It was a three span continuous railroad bridge using four CFT girders with diameter of 1.3 m [9, 10].

In most of previous studies, the main considerations of experiment were the slenderness ratio of steel

tube and the strength of concrete core. They also reported that the slip between steel tube and concrete core did not have much effect on the flexural capacity of the CFT beams.

Nematzadeh and Naghipour offered an innovative technique which not only it increases the workability, but also remarkably increases the compressive strength and modulus of elasticity of the concrete. In this technique, concrete is produced by compressing the fresh concrete without incorporating additives and no need for external vibration and workability control. By applying this technique, excess water is completely expelled out from the fresh concrete and porosity is remarkably decreased [11, 12].

One of the important parameters need to be taken into account is relation between easy mixing and placement and ultimate performance of structural member regard to its cost. It should be noted that none of the previous researches investigated a HPC without any additive. So, in this study, the effects of HPC mixture (without additive) of the concrete core on the flexural behavior of the CFT beams has been investigated. This study is done in two phases. In the first phase, a new economic high performance concrete mixture is introduced. Then compressive strength test was done on cubic specimens with that innovative HPC mixture. Results showed that new proposed HPC mixture not only increases the workability, but also no reduction in compressive strength is observed. In the second phase, the effect of this HPC mixture on the passive and active confined concrete beams was investigated. Moreover, all specimens have circular sections. Three-point static loading test was performed for all specimens. The ultimate strength, ductility, concrete core's cracking/crushing pattern and failure mode of all specimens with conventional and HPC mixture were compared.

2 Experimental Program

2.1 General Description

This study was done on two different phases. In the first phase, the effect of the HPC mixture on the compressive strength has been investigated. And in the second phase, flexural behavior of active and passive specimens were examined. Two HPC and two CC mixtures were chosen to investigate the effect of various compressive strength and method of mixture of the concrete core on the flexural

behavior of the CFT beams. Specimens were categorized in two groups. One group was made with CC mixture, as a reference and the other one was built with HPC mixture. In each group, there were two types of specimens (passive and active). In the first step, active specimens were placed in pressure apparatus and initial pressure was applied on them. In the second step, flexural bending test was done on all specimens.

2.2 Instrumentation

In the first step, an initial pressure is applied on the active specimens. In order to exert pressure on specimens for a certain period of time, special equipment was designed and built, which called pressure apparatus. The pressure apparatus and procedure for applying initial pressure was fully described in Naghipour et al. [13].

In this study, all specimens were under short term pressure. Specimens had been taken out of the pressure apparatus when no more water was expelled out of the specimen.

2.3 Material

-concrete: Two different types of mixtures were considered and specimens were divided in two groups. For each group, two different compressive strengths were regarded (25MPa and 35MPa).

As described before, this study was done on two phases. In the first phase, cubic specimens with HPC mixture were built in order to assure that proposed concrete mixture is suitable for next phase. Two different compressive strengths were considered. In the second phase, beam specimens were built with both CC and HPC mixtures.

In CC mixture, all mix designs and proportion were developed in accordance with ACI 211 [14] and only commercially available materials were used. But in HPC mixture, concrete is mixed based on the following assumption. It is assumed that, for a specific strength of the concrete, all material proportion was the same as material proportion of the CC mixture with higher compressive strength except for water. Water proportion was calculated from (w/c) ratio of that specific compressive strength.

In all concrete mixes, the maximum aggregate size was 9.5 mm. Also, Type II Portland cement was used. Moreover, no admixture was used as they would effect on the effectiveness of the present technique on the compressive strength of the

concrete core, and flexural behavior of the specimens. Table 1 shows details of different concrete mixture.

Table 1 - Mix proportions per 1 m³ concrete

Type of mixture	HPC		Conventional	
	25	35	25	35
f _c (MPa)	25	35	25	35
W/C	0.62	0.48	0.62	0.48
Coarse aggregate (kg)	661.2	661.2	703.9	703.9
Fine aggregate (kg)	806.7	806.7	994	888.2
Cement (kg)	592.1	592.1	362.9	468.8
Water (kg)	367.1	284.2	225	225

In the second phase, the mixes of PCFT specimens were cast without vibration or compaction. However, the reference concrete specimens (CFT) are molded into steel tubes by compaction in three layers without external pressure.

-Steel: The current AISC manual Sec I2a [15], specifies that the cross section area of the steel portion should be greater than 1% of the total cross sectional area of a CFT member. If the tube is too thin, it does not provide sufficient confinement to develop the full plastic capacity of the concrete [2]. As a result of local buckling of the tube wall, the plastic moment capacity is not fully developed [5].

In this experimental study, conventional circular steel tube, with 60 mm diameter and 2 mm thickness was used for all specimens which satisfied the limitation of AISC manual Sec I2a [15]. The nominal yield stress and ultimate stress of the tube were 435MPa and 500MPa, respectively.

3 Test Specimens

3.1 First Phase

In this phase, twelve cubic specimens were built per compressive strength. After two days, molds were removed and cured continuously in saturated condition before being tested, in accordance with standard practice ASTM C192/C192M [16]. These specimens were tested after 7, 14, 21 and 28 days following concrete casting.

3.2 Second Phase

In this phase, the effect of expelling the excess water out of fresh concrete on the flexural behavior of CFT was investigated with two different types of

concrete mixture. Therefore, the specimens were prepared by changing the concrete mixture. In each group, initial pressure was applied on half of the specimens by pressure apparatus.

All specimens had identical length equal to 1 meter. According to ACI 211, the specimen dimensions were taken to be at least three times more than the maximum size of concrete [14]. Nonetheless, the length to diameter ratio (L/D) of specimens is 11.

All specimens were cured in ambient condition at room temperature for 28 days, vertically. Five cubic specimens were built for each specimen, in order to measure the strength of reference concrete. Cubic specimens were demolded after 2 days and they were cured continuously in saturated condition before being tested.

In this phase, ten specimens were built in two groups with HPC and CC mixture. In each group, there were two sub-groups with equal compressive strength of the concrete core. Furthermore, in each sub-group, half of specimens were built without initial pressure (CFT) and rest of them were built by applying initial pressure on them (PCFT). Details of specimen's properties are presented in Table 2. The initial pressure equal to 30MPa was applied on active specimens.

As Table 2 shows, each specimen label has four parts. At the first part, the letter "S" stands for the word "static", indicating that the specimen is under static loading. And the number represents the compressive strength of concrete core in MPa. In the second part, letters "A" and "P" represent active and passive confinement, respectively. In the third part, the letter S is used for specimens with HPC mixture while the letter C is used for specimens with CC mixture. And number in the fourth part represents number of specimens.

Table 2 Specimen's detail

Specimen identifier	group	Type of confinement	Type of concrete mixture	f _c MPa
S35- A-S-1 S35- A-S-2	A	Active	HPC	35
S35- P-S-1 S35- P-S-2		Passive		
S25- A-S-1 S25- A-S-2		Active		25
S25- P-S-1 S25- P-S-2		Passive		
S35- A-C-1 S35- P-C-1	B	Active	CC	35
S35- P-C-1		Passive		
S25- A-C-1		Active		25
S25- P-C-1		Passive		

3.3 Experimental Set Up

In the first phase, compressive strength test was carried out on all cubic specimens. And in the second phase, all CFT and PCFT specimens were examined in 3-point bending test. Tests were described in the following sections in details.

3.3.1 Compressive Strength Test

Compressive strength test of cubic specimens of first phase were carried out using a 2000KN capacity ELE testing machine in 7, 14, 21 and 28 days since the date of concrete casting. The load has been increased based on a load-controlled strategy until significant strength decay was recorded, which indicates failure of the specimens. Ultimate strength of each specimen was recorded.

3.3.2 Flexural Test

A 3-point bending test was prepared, using 150 KN capacity SANTAM testing machine (made in Iran), under stroke control at a rate of 2mm/min (Fig. 1). Experimental set-up with shear span ratio of 5.5 was designed.



(a)

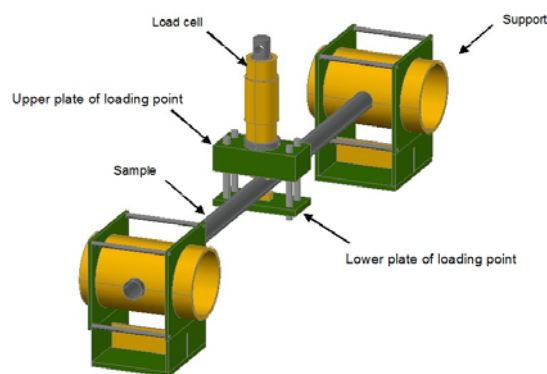

(b)

Fig. 1 Test set up (a) experimental and (b) schematic view

4 Results and discussion

4.1 Results of First Phase

The results of compressive strength tests of the first phase are represented in Table 3.

As it seen in Table 3, compressive strength of HPC mixture are almost same as target compressive strength. So it shows the effectiveness of considered assumption in HPC mixture design. HPC mixture has higher workability with the same or higher compressive strength without adding additives.

Table 3 Results of compressive strength test- First phase

Date of test	Group B		Group A	
	$f_c=25$ MPa		$f_c=35$ MPa	
	Mean (MPa)	Measured (MPa)	Mean (MPa)	Measured (MPa)
7 days	16.68	17.37	26.8	32.38
		15.98		31.35
		16.69		-
14 days	21.36	21.92	36.46	34.56
		20.58		36.83
		21.58		37.98
21 days	23.34	23.58	36.86	37.5
		22.07		36.22
		24.38		-
28 days	25.05	26.14	38.46	39.76
		24.78		37.5
		24.25		37.91

4.2 Results of Second Phase

4.2.1 Load-deflection relationship and failure mode

Fig. 2 shows the load-deflection diagram of specimens. As it seen, all specimens have ductile behavior which indicates that the load- deflection diagram of the specimens shows a plastic behavior once the steel tube yields.

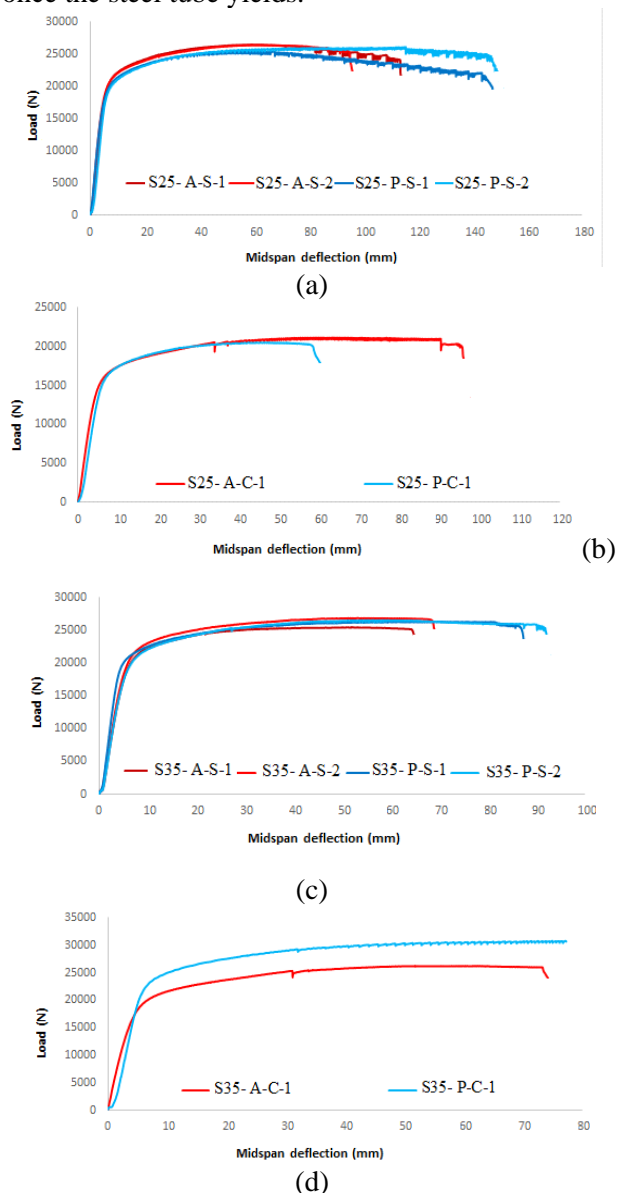

Fig. 2 Load- deflection diagram (a) specimens with $f_c=25\text{MPa}$ and HPC mixture, (b) specimens with $f_c=25\text{MPa}$ and CC mixture, (c) specimens with $f_c=35\text{MPa}$ and HPC mixture and (d) specimens with $f_c=35\text{MPa}$ and CC mixture

As shown in Fig. 2, in specimens with HPC mixture, passive confined specimens have more ductile behavior in comparison with active confined specimens. It means that active confinement

changes the behavior of specimens, while little change occurs in ultimate capacity of specimens. But in specimens with CC mixture, passive confined specimens behaved in a less ductile manner unlike active confinement specimens. It should be noted that, type of concrete mixture (HPC or CC mixture) had not significantly affected the ultimate capacity of specimens.

For HPC mixture of concrete core, by increasing the compressive strength of the concrete core, ultimate strength of specimens was almost constant but the behavior was changed. In the other word, specimens with $f_c=25\text{MPa}$ showed more ductile behavior than specimens with $f_c=35\text{MPa}$. But for CC mixture of the concrete core, for both passive and active confined specimens, an increase in the compressive strength of the concrete core led to an increase in the ultimate capacity of specimens. Although specimens with $f_c=35\text{MPa}$ behaved more brittle than specimens with $f_c=25\text{MPa}$.

Fig. 3 shows types of failure for all specimens. So, in tensile zone, the steel tube was cracked, and in compression zone, the local outward buckling in the steel tube was visible.

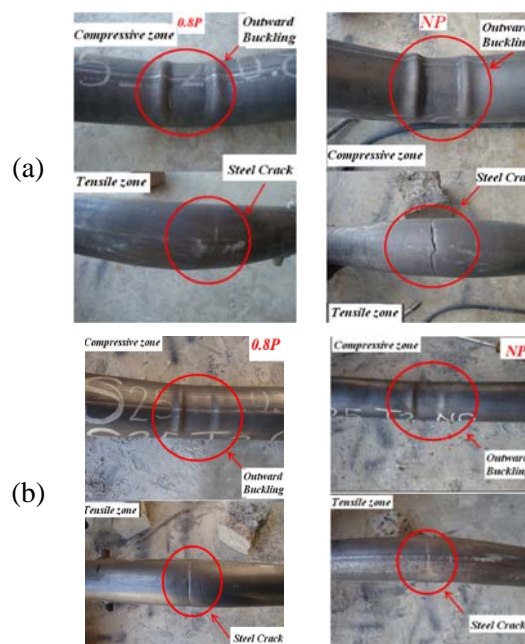

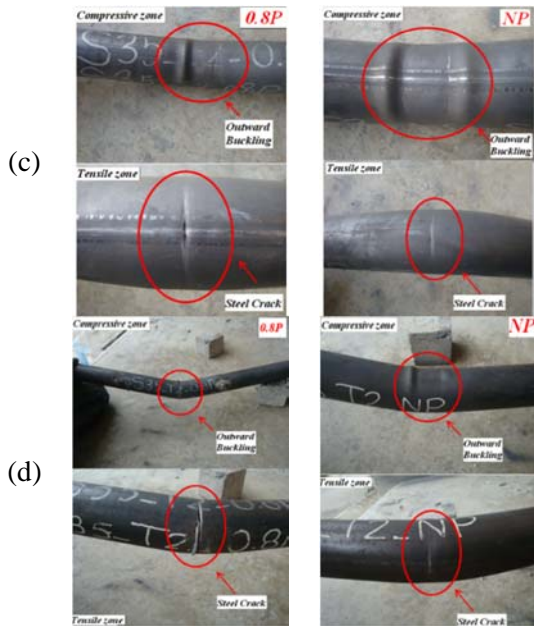

Fig. 3 failure mode (a) specimens with $f_c=25\text{MPa}$ and HPC mixture, (b) specimens with $f_c=25\text{MPa}$ and CC mixture, (c) specimens with $f_c=35\text{MPa}$ and HPC mixture and (d) specimens with $f_c=35\text{MPa}$ and CC mixture

In active specimens with CC and HPC mixture, specimens with $f_c=25\text{MPa}$ showed slighter outward buckling in compression zone unlike passive ones. However, for $f_c=35\text{MPa}$, slight distortion occurred in the steel tube especially in HPC specimens. Moreover, by comparing similar specimens, with different types of concrete mixture, it could be concluded that outward buckles in compression zone were more severe in HPC mixture than CC ones.

4.2.2. Cracking pattern

After flexural test, parts of the steel tube in both compression and tensile zones was removed in order to reveal the concrete cracking and crushing pattern (Fig. 4). Flexural cracking is clearly visible in all specimens. Although, in compression zone due to the loss of confinement in the location of steel tube's outward buckling the concrete core locally failed.

For specimens with $f_c=25\text{MPa}$ and HPC mixture, friction between the steel tube and the concrete core increased in both active and passive specimens, so parts of the concrete core in tensile zone has been attached to the steel tube (Fig. 4(a)). But for specimens with CC mixture, in tensile zone the steel tube and the concrete core were separated easily. Moreover, for specimens with $f_c=35\text{MPa}$, the interaction between the concrete core and the steel tube was lower.

For $f_c=25\text{MPa}$ and active confinement situation, for $f_c=25\text{MPa}$, severe cracks in tensile zone and slight concrete crushing in compressive zone was observed in specimens with HPC mixture while in specimens with CC mixture, very slight concrete crushing was observable.

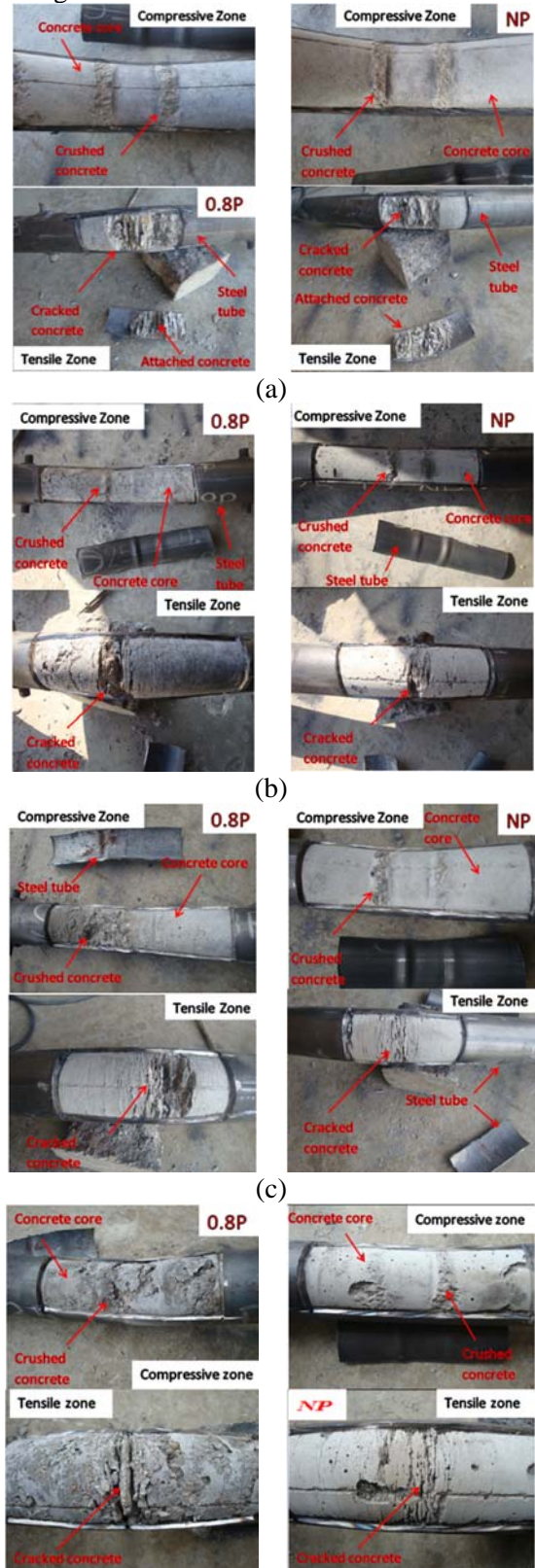

(d)

Fig. 4 Concrete core of specimens after testing (a) $f_c=25\text{MPa}$ -HPC, (b) $f_c=25\text{MPa}$ -Conventional, (c) $f_c=35\text{MPa}$ -HPC and (d) $f_c=35\text{MPa}$ -Conventional

4.2.1 Moment Capacity and absorbed energy

The moment capacity (M_u) and absorbed energy (E_{abs}) of beam specimens is represented in Table 4. As it shows, in active specimens, using HPC mixture increases the M_u and E_{abs} , simultaneously. Furthermore, using HPC mixture could be more effective for lower compressive strength. Also, it can be concluded that ultimate flexural capacity of specimens with HPC mixture was almost the same. Thus, for specimens with HPC mixture, f_c did not affect the ultimate capacity.

Table 4 Moment capacity of tested specimens

Specimen identifier	Confinement type	M_u KN.m	P_u KN	E_{abs} KN.m
S35-0.8P-S-1	Active	4.2	25.46	1.62
S35-0.8P-S-2		4.43	26.87	1.87
S35-0.8P-C-1		3.8	23.00	1.57
S35-NP-S-1	Passive	4.20	25.47	3.53
S35-NP-S-2		4.39	26.58	2.27
S35-NP-C-1		4.08	24.72	1.24
S25-0.8P-S-1	Active	4.37	26.48	2.8
S25-0.8P-S-2		4.35	26.39	2.36
S25-0.8P-C-1		3.49	21.18	1.89
S25-NP-S-1	Passive	3.32	20.12	1.64
S25-NP-S-2		3.21	19.48	2.02
S25-NP-C-1		3.39	20.52	1.13

4.2.2 Parametric Study

4.2.2.1 Confinement Type

In order to evaluate the effect of confinement type on the flexural behaviour, the composite specimens are divided into three groups, each group has same type of concrete mixture, including passive and active confinement with two values of f_c (as subgroups). In Fig. 7, the results of active specimens including M_u and E_{abs} are compared with M_u and E_{abs} of passive specimens (as reference specimen).

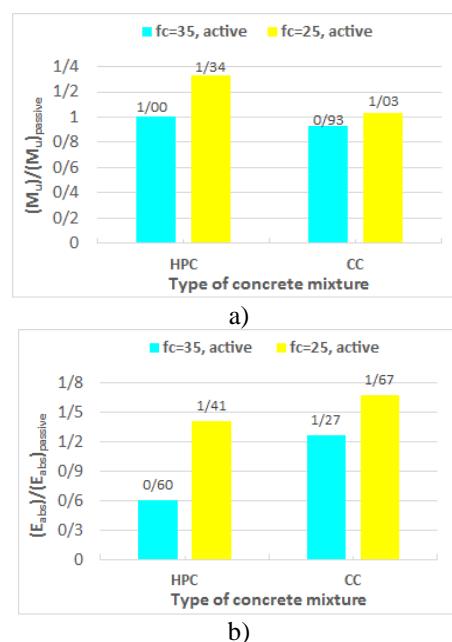

Fig. 5 Percentage of variation – effect of confinement type; a) M_u b) E_{abs}

As seen in Fig. 5(a), 5(b), for $f_c=25\text{MPa}$, active confinement increases M_u and E_{abs} in both CC and HPC mixtures. But for $f_c=35\text{MPa}$ and CC mixture, however M_u is reduced by 7% as the confinement type is changed, E_{abs} is increased by 27%. While in specimens with HPC mixture and $f_c=35\text{MPa}$, active confinement is decreased E_{abs} by 40% without any changes in M_u .

It can also be concluded that active confinement has the best performance in specimens with $f_c=25\text{MPa}$ and HPC mixture. Also, the worst performance belongs to specimens with $f_c=35\text{MPa}$ and HPC mixture.

4.2.3 Concrete Compressive Strength

The effect of compressive strength of concrete core was investigated on the flexural behaviours. All specimens are categorized into two groups; in each group, initial applied pressure and type of concrete mixture are the same for different compressive strengths.

To determine the variation in M_u and E_{abs} by increasing the compressive strength of concrete core, the percentage of change in M_u and E_{abs} for specimens with $f_c=35\text{MPa}$ are compared with (M_u) and (E_{abs}) for specimens with $f_c=25\text{MPa}$ (as reference specimen) in Fig. 6.

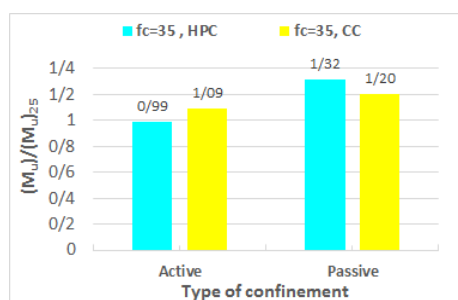

a)

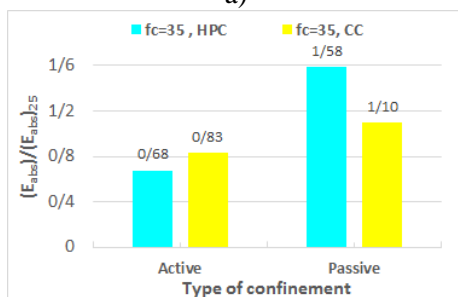

b)

Fig. 6 Percentage of variation – effect of f_c ; a) M_u b) E_{abs}

It is evident that for specimens with $f_c=35$ MPa, increasing the compressive strength of concrete core, leads to lower values of E_{abs} . It is obvious that, in passive specimens increasing the f_c have better performance in HPC mixture than CC mixture. It could be concluded that M_u of passive specimens increases more than 20% with increasing the compressive strength of concrete core, while M_u of active specimen is increased less than 10%. In passive specimens with HPC mixture, improvement of E_{abs} due to concrete strength increase is about 60%, whereas it is about 10% for specimens with CC mixture.

4.2.4 Method of Concrete Mixture Design

For studying the difference between CC and HPC mixtures on M_u and E_{abs} of CFT beams, specimens are categorized in a way that compressive strength of the concrete core and confinement type are same for specimens with both CC and HPC mixtures. To study the effects of method of concrete mixture design on the specimen flexural behaviour, the percentage of change in M_u and E_{abs} of specimens with HPC mixture are calculated in comparison with specimens which have CC mixture (as reference specimen) and shown in Fig. 7.

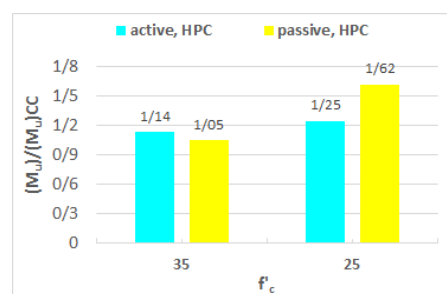

a)

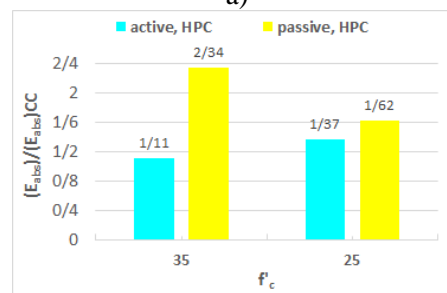

b)

Fig. 7 Percentage of variation – effect of Method of concrete Mixture Design; a) M_u b) E_{abs}

As shown in Fig. 7, it is evident that in all cases, using HPC mixture, leads to increment in values of M_u and E_{abs} . Passive specimen with $f_c=25$ MPa has the best performance (both M_u and E_{abs} are increased 62%). For passive specimens with $f_c=35$ MPa, E_{abs} has the maximum increment around 134%. While the maximum increment of M_u is occurred in passive specimens with $f_c=25$ MPa.

5 Conclusion

The flexural behaviour of active and passive concrete filled steel tubes with conventional and high performance concrete mixture was investigated experimentally in this study. Twelve CFST specimens were tested under flexural loading. Compressive strength of specimens with HPC mixture were same as target compressive strength, which shows the effectiveness of adding water to concrete mixture with higher f_c in order to increase W/C ratio for design of concrete mixture. Thus, this mixture had a higher workability without adding additives. Also, since specimens with HPC mixture has higher M_u , E_{abs} and workability especially in active specimens so it is recommended to use HPC mixture instead of CC mixture in CFST beams. Moreover, using HPC mixture in active specimens with low compressive strength, lead to suitable performance of these specimens.

References:

- [1] Lu, Y.Q., Kennedy, D. J. L., The Flexural Behavior of Concrete-Filled Hollow Structural Section, *Canadian journal of civil engineering*, Vol 21, No 1, 1994, pp. 111-130.
- [2] Aaron, D., Thomas, H. K., Chris, R. and Uksun, K. , Composite Flexural Behavior of Full-Scale Concrete Filled Tubes without Axial Loads, *Journal of structural engineering*, 2010, 1401-1412.
- [3] Elchalakani, M., Zhao, X. L., Grzebieta, R. H., Concrete-Filled Circular Steel Tubes Subjected to pure Bending, *Journal of Constructional Steel Research*, Vol 57, No 11, 2001, pp. 1141-68.
- [4] Furlong, R. W., Strength of Steel-Encased Concrete Beam-Columns, *Journal of Structural Division*. ASCE, Vol 93, No ST5, 1967, pp. 113-24.
- [5] Prion, H. G. L., Boehme, J., Beam-Column Behavior of Steel Tubes Filled with High Strength Concrete. *Canadian journal of civil engineering*, Vol 21, No 2, 1994, pp. 207-218.
- [6] Tomii, M., Sakino, K., Elasto-Plastic Behavior of Concrete Filled Square Steel Tubular Beam-Columns, *Transactions of Architectural Institute of Japan*, Vol 280, 1979, pp.111-20.
- [7] Uy, B., Strength of Concrete Filled Steel Box Columns Incorporating Local Buckling, *Journal of Structural Engineering*. ASCE, Vol 126, No 3, 2000, pp. 341-52.
- [8] Han, L. H., Flexural Behaviour of Concrete-Filled Steel Tubes, *Journal of Construction Steel research*, Vol 60, No 2, 2004, pp. 313-37.
- [9] Hosaka, T., Umehara, T., Nakamura, S., Nishiumi K., Design and Experiments on A New Railway Bridge System Using Concrete Filled Steel Pipes, *ASCCS seminar. Concrete filled steel tubes. A comparison of international codes and practice*. Innsbruck, Austria, 1997, pp. 367-372.
- [10] Nakamura, S., Momiyama, Y., Hosaka, T. and Homma, K., New Technologies of Steel/Concrete Composite Bridges, *Journal of civil engineering*, Vol 58, 2002, pp. 99-130.
- [11] Nematzadeh, M., Naghipour, M., Compressing Fresh Concrete Technique and the Effect of Excess Water Content on Physical-Mechanical Properties of Compressed Concrete, *Materials and design*, Vol 37, 2012, pp. 256-267.
- [12] Nematzadeh, M., Naghipour, M., Compressive Strength and Modulus of Elasticity of Freshly Compressed Concrete. *Construction and building materials*, Vol 34, 2012, pp.476-485.
- [13] Naghipour, M., Nemati, M., Jalali, J., Nematzadeh, M., The Effect of Active Confinement and shear key Elements on the Flexural Behavior of Concrete Filled Steel Tube (CFST), *Journal of civil and environmental engineering*, Vol 46.2, No 83, 2016, pp. 57-70.
- [14] ACI 211.1-91 Committee, *Standard practice for selecting proportions for normal, heavyweight, and mass concrete*, ACI manual of concrete practice. part 1, Michigan (USA), American concrete institute. 38, 2000.
- [15] AISC, *Steel construction manual*, American Institute of Steel Construction. 13th Ed., Chicago, 2005.
- [16] ASTM C192 / C192M-16a, *Standard Practice for Making and Curing Concrete Test Specimens in the Laboratory*, ASTM International, West Conshohocken, PA, 2016, www.astm.org.