

# Visible Light Communication for Audio Signals

SIMONA RIUREAN, RAZVAN STOICA, MONICA LEBA

Department of Electrical and Computer Engineering

University of Petrosani

Str.Universitatii, nr.20, Petrosani

ROMANIA

[sriurean@yahoo.com](mailto:sriurean@yahoo.com), [razvan.stoica@jvsensorventures.com](http://razvan.stoica@jvsensorventures.com), [monicaleba@yahoo.com](mailto:monicaleba@yahoo.com)

*Abstract:* - Is in human nature to be curious and aspire for more and better. In the last two decades, wireless communication systems spread unexpected fast and wide. Currently, total radio frequency (RF) wireless data traffic exceeds 11 Exabyte per month, creating a 97% gap between the traffic demand per device and the available data traffic per device in the mobile networks. This is the reason why RF wireless communication bottleneck is closely expected. Optical wireless communication (OWC), as a future reliable alternative, meets unprecedented spread in the last two decades, new and interesting implementations bringing hopes for its bright future. The paper shows an experimental electronic Rx-Tx prototype for one-way sound communication, in line-of-sight (LOF), optical communication through visible light. Visible light communication (VLC) concept, one of the OWC subsequent, is expected to bring indoors, not only illumination, but data traffic, as well.

*Key-Words:* - OWC, VLC, sound data communication by light,

## 1 Introduction

We can find in almost all cultures, over time, diverse kind of examples of OWC in a form of beacon fires or smoke signal. The first technological implementation of optical communication has been done in 1792 by French engineer Claude Chappe who built the first optical telegraph network. 196 information symbols encoded in a position of two arms connected by a crossbar were transmitted by semaphore towers. Morse code invented in 1836 is another example of communication based on signal lamp message to on-shore lighthouse for navigation. Bell demonstrated in 1880 the first implementation of a free-space optical (FSO) link in a form of a photophone [1] by modulating a voice message onto a light signal. The real potential of OWC was revealed by Gfeller and Bapst in 1979 who demonstrated the potential of OWC indoor networks [2]. The system implemented by them in the IR spectrum, the wavelength of 950 nm, was able to achieve 1 Mbps using on-off keying modulation (OOK).

For a time already, we witnessed reports of remarkable achievements such as high speed data rate (3.5 Gbps) from a single colored light emission diode (LED) in a single-input-single-output (SISO) setting made by Tsonev *et.al.*[3].

Even better, in laboratory conditions, in 2015, a team from Oxford University reached a bit rate of

224 Gbps, which is 100s of times faster than our average WI-FI connection at home or office. They demonstrated an indoor optical bidirectional wireless link with an aggregate capacity over 100 Gb/s. The link operates over ~3 m range at 224 Gb/s (6 x 37.4 Gb/s) and 112 Gb/s (3 x 37.4 Gb/s) with a wide field of view (FOV) of 60° and 36°, respectively [4].

Several implementations in different area of optical indoor wireless communication encourages new and visionary solution for wireless VL communication.

We are excited by the possibility of implementing this emerging technology in educational systems and thus our first step to the development of a VLC is the prototype presented into this paper.

## 2 Visible Light Communication Prerequisite and Requirements

VLC systems offer essential technical and operational advantages, such as low power requirements, much larger bandwidth capacity (from 380 to 750 nm, 430 to 790 THz which is a factor of 10,000 larger than the RF spectrum) absence of electromagnetic interference and quite a large spectrum.

It can be useful on a large domain of communication applications, beginning with

millimetres range interconnected within integrated circuits through outdoor kilometres links [5].

VLC is intended to use LEDs as emitter and PD as receiver. Infrared signals were used for wireless data transmission applied to indoor wireless local area networks [6]. The wavelengths of infrared and visible light sources are close to each other, and the signals, therefore, qualitatively reveal a similar propagation behaviour. As a consequence, white LEDs have started to attract attention for use as a data communication means [7]. Moreover, white LEDs have very high brightness, very low power consumptions and long lifetime. For that reason, a unique feature of white LEDs is that they can serve two purposes at the same time: lighting and high speed wireless data transmission. In addition, unlike infrared transmission, there are no health regulations to restrict the transmit power receiver in a one-way network. [8]

Since white LEDs are currently implemented in many domains of our everyday life, they are predicted to replace high energy consuming light bulbs indoors and provide at the same time wireless data communication in many day life used areas such as street lamps, headlights of planes and trains, front and back lights in cars and trains, for object illumination in museums, subways, hospitals, petrochemical and nuclear industry and so on. [9]

The optical medium can be viewed as complementary to the radio medium rather than competitive. For example, if a WLAN (Wireless Local Area Network) is required to cover a large area, where users can roam freely inside and outside a building and remain connected to the network at all times, then radio transmission is the best choice to achieve this. If, however, a WLAN is required to cover a relatively small area, and the service is provided locally inside a room, but high transmission rates are required such as for video conference, digital television (TV) or video on demand, then the optical transmission with almost unlimited bandwidth can be used. At the same time, this would free radio frequency spectrum for other purposes as described above.

Half a decade ago, on 2011, the VLC technology has been coined as LiFi by the physician, professor Harald Haas during a TED talk. Due the parallel between LiFi and Wi Fi and the demonstrated possibility of replacing the wireless communication Wi-Fi in certain places and situations with LiFi, the impact was strong and many implementations have been noticed since.

LiFi refers to the complete high speed, bidirectional, multiple-input multiple-output (MIMO) network using VLC for data download and different existing

alternative solution for upload data. Wireless LiFi network as complement of Wi Fi, would provide significant spectrum release by allowing cellular and wireless fidelity systems to off load a significant portion of wireless data traffic. [10]

Our purpose here is to demonstrate practically the physical possibility of sound communication through light.

### 2.1 Visible Light Communication Wireless System Model

The analogue communication through light is demonstrated by this prototype. The prototype presented here is intended to transfer audio source through light and receive it by the Rx which is placed few centimeters away from Tx.

Since LEDs are semiconductors devices, they are perfectly compatible for handling digital data without any form of distortions. A LED will replicate and transmit the input content exactly as it was in the original source, and this property make LEDs extremely easy to configure for the intended purpose.

Transmitter consists of 3 transistors and few passive components paired with 1 watt LED. Transmitter is meant to changes LED's brightness with respect to audio signal. Changes in brightness due to audio signal will be slightly visible to human eye, so a static illumination of white LED is normally perceived by our eyes.

The receiver consists of a photo detector (PD) which is paired with the amplifier and the sound output is given by the speaker.

The PD operates by converting light signals that hit the junction to a voltage or current. The junction uses an illumination window with an anti-reflect coating to absorb the light photons. The result of the absorption of photons is the creation of electron-hole pairs in the depletion region. Since photodetectors have sufficiently fast response that provide a measurable output for a small amount of light and economical, they are worth using for applications in high-speed optical communications.

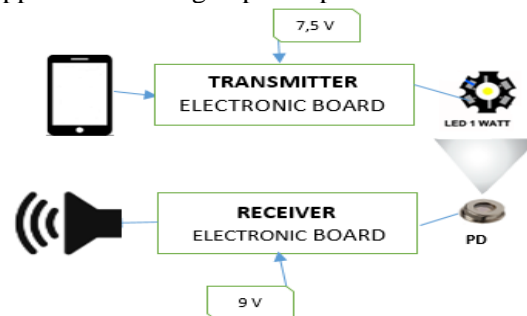

Fig. 1. The block diagram of the prototype

Figure number 1 shows the principle block diagram of the prototype. It consists of two boards, one for the transmitter (Tx) and one for receiver (Rx).

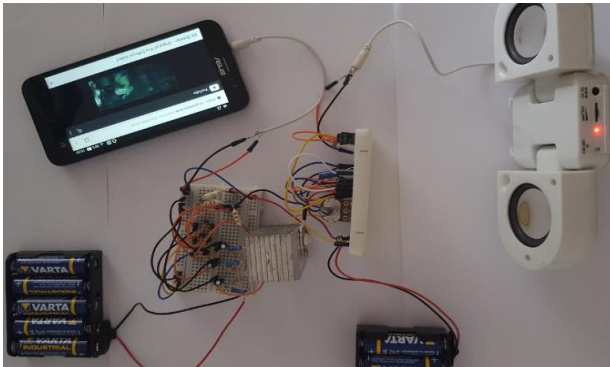

Fig. 2. The wireless VLC prototype developed

### 2.1.1 Tx Component description

For an audio source we use a mobile phone.

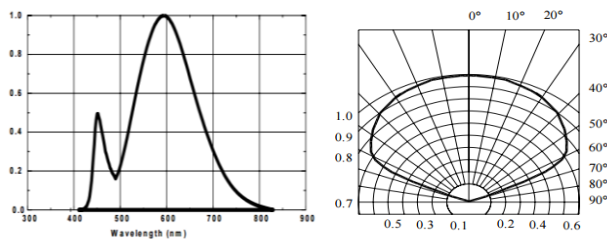

Fig. 3. Wavelength of LED used and its relative radiant sensitivity vs. angular displacement

The transmitter is transistorized amplifier which consists of 3 amplifiers connected in parallel to drive the 1 watt white LED. Each transistor base consists of voltage divider which gives necessary bias for the individual transistor. The input stage has capacitors at each transistor's base for blocking DC signals which could degrade the quality of output.

White LEDs are classified into two types. Some are fabricated using a blue LED chip and a phosphor. These types of LEDs have a phosphor layer on top of an InGaN-bases blue LED chip. The other types of white LEDs are fabricated by mixing light from LEDs of the three primary colours, such as red, green, and blue. All the three colours are emitted simultaneously.

The PCB layouts and schematic capture were made using Proteus application in order to test first our circuit diagram. Simulating first the proper functionality of the concept, is the best idea to start a project. The use of Proteus Professional application proves to be a suitable tool for this purpose. Proteus is a software which can be used to draw schematics, PCB layout, code and even simulate the schematic capture.

The optical source used in the prototype is a single chip (the first type as described above) 5mm white

cold LED. We choose this type as it can be considered standard and not expensive. LED's wavelengths and its radiation diagram are shown in figure 3.

### 2.1.2 Rx Component description

The Low Voltage Audio Power Amplifier LM386 is a power amplifier designed for use in low voltage consumer applications.

The gain is internally set to 20 to keep external part count low, but the addition of an external resistor and capacitor between pins 1 and 8 will increase the gain to any value from 20 to 200. The inputs are ground referenced while the output automatically biases to one-half the supply voltage. The LM386 ideal for battery operation.

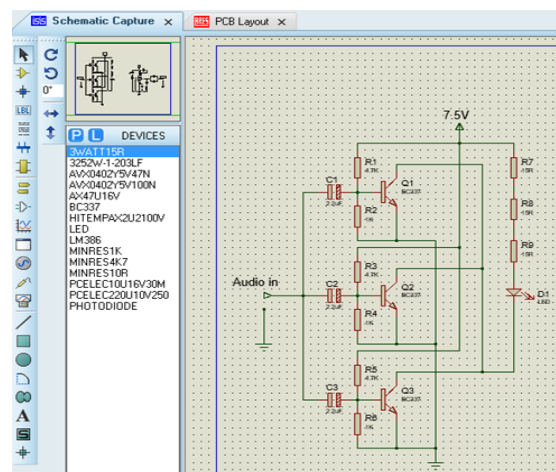

Fig. 4. Tx schematic capture and PCB Layout

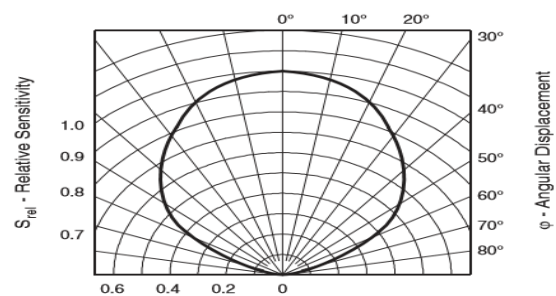

Fig. 5. Relative Radiant Sensitivity vs. Angular Displacement

The PD used here is characterized by certain key parameters: spectral response, photosensitivity, quantum efficiency, dark current, forward-biased noise, noise equivalent power, terminal capacitance, timing response (rise time and fall time), frequency bandwidth, and cut off frequency.

For the audio play at Rx we use a speaker where a loud and clear song is heard.

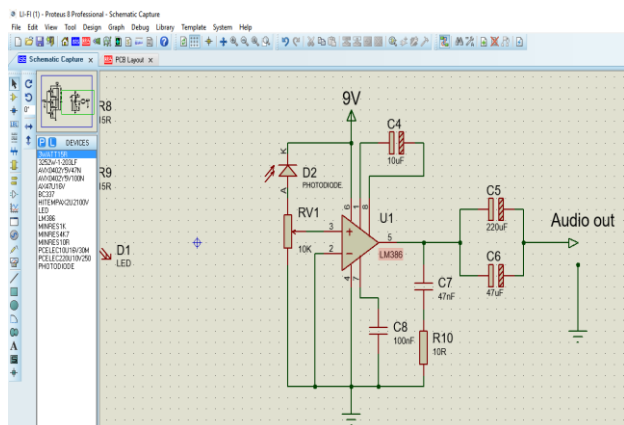

Fig. 6. Rx schematic capture and PCB Layout

### 2.2. Data quality transmission

We demonstrated practical that, using a LED and a PD, sound can be wireless communicated through light.

Even if the distance achieved here is not a gain, the speed of wireless transmission as well as accurateness of data were successfully achieved at an encouraging rate.

These can be seen on the oscilloscope screen in figure number 7.

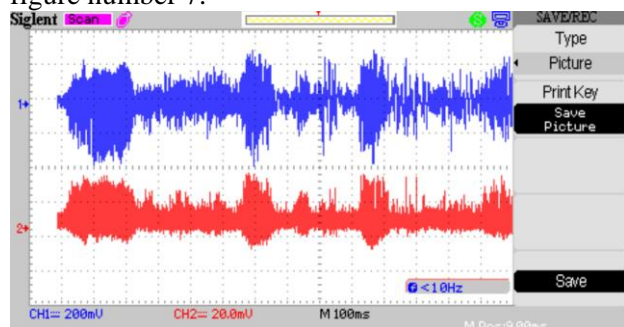

Fig. 7. Tx and Rx accurateness

### 3 Conclusions

A wireless VLC prototype was developed. The transmission is based on the assumptions of direct line-of-sight (LOS) and simplex channel conditions. It was demonstrated that the white LED based on visible light data transmission system for wireless sound communication is indeed technically feasible. The tests were carried out under indoor ambient light (both natural light and artificial illumination) conditions. In these condition of strong interference, it is shown that a clear sound was communicate and achieved at a distance of about 3 cm with only a single white cold LED. It is demonstrated that larger coverage can be obtained by using LED arrays. Moreover, the wireless channel needs to be

characterized and models for it have to be developed.

Furthermore, issues of optical power leakage from the transmitter to receiver will have to be addressed in order to enable full duplex communication.

All these are subjects of the future work in order to achieve high speed, long distance VLC wireless data communication.

#### References:

- [1] A. G. Bell “Selenium and the Photophone”, *Nature*, Vol. 22, No. 569, 1880, pp. 500-530.
- [2] F.R. Gfeller, U. Bapst “Wireless In-House Data Communication Via Diffuse Infrared Radiation”, *Proceedings of IEEE*, vol. 67, no. 11, pp 1474 – 1486, Nov. 1979.
- [3] D. Tsonev, H. Chun, S. Rajbhandari, J.D. McKendry, S. Videv, E. Gu, M. Haji, S. Wattson, A. Kelly, G. Faulkner, M. Dawson, H. Haas and D. O’Brien. “A 3-Gb/s Single-LED OFDM-Based Wireless VLC Link Using a Gallium Nitride  $\mu$ LED”. *IEEE Photonics Technology Letters*, volume 99, p. 4, 2014.
- [4] A. Gomez, K. Shi, C. Quintana, M. Sato, G. Faulkner, B. C. Thomsen, Dominic O’Brien “Beyond 100-Gb/s Indoor Wide Field-of-View Optical Wireless Communications”, *IEEE Photonics Technology Letters* (Volume: 27, Issue: 4, pp. 367 - 370 Feb.15).
- [5] “Li-Fi via LED Light Bulb Data Speed Breakthrough” *BBC News*, Oct 2013, <http://www.bbc.co.uk/news/technology-24711935>.
- [6] Murat, C. Capsoni, Z. Ghassemlooy, A. Boucouvalas, E. Udvary “Optical Wireless Communications an Emerging Technology” *Springer International Publishing Switzerland* 2016
- [7] J. Kahn and J. Barry, “Wireless Infrared Communications,” in *Proceedings of the IEEE*, vol. 85, February 1997, pp. 265–298.
- [8] T. Mukai and S. Nakamura, “White and UV LEDs,” *Oyo Buturi*, vol. 68, pp. 152–155, 1999.
- [9] S. Dimitrov, H. Haas, “Principles of LED Light Communications Towards Networked Li-Fi. Cambridge CB2 8BS, United Kingdom: Cambridge University Press, 2015.
- [10] M.Risteiu, R.Dobra, M.Leba, A.Ionica, A Smart House in the Context of Internet of Things, *International Journal of Internet of Thinks and Web Services*, vol. 1, 2016 pp. 38-42, ISSN 2367-9115