

Real-Time Indoor Air Quality Monitoring Through Wireless Sensor Network

MOHIEDDINE BENAMMAR
mbenammar@qu.edu.qa

ABDERRAZAK ABDAOUI
aabdaoui@qu.edu.qa

H.M. SABBIR AHMAD
sabbir@qu.edu.qa

FARID TOUATI
touatif@qu.edu.qa

ABDULLAH KADRI
abdullahk@qmic.qa

Abstract: Recently, indoor air quality monitoring (AQM) has become an important research area for the concern of human health and lifestyle. The AQM is usually based on the deployment of wireless sensor networks (WSN) within the building. Bridging the gap between gas sensors, deployed at different locations of the WSN, and the Internet becomes a challenging task in terms of link reliability and data integrity. Recent advances in the design of Internet-of-Things (IoT)-enabling solutions are spurring the advent of novel and fascinating bridging. In the wake of this tendency, this paper proposes a novel, IoT Smart architecture for air quality monitoring. With the IoT vision, we propose a Smart global AQM system, which employs different, yet complementary, technologies, such as gas sensing, WSN and Smart mobile. Our proposed system, is able to collect, in real time and from different cities, data related to the concentrations of critical gases, humidity, and temperatures. Collected data are delivered to a local gateway where an advanced processing makes them easy and accessible by both, local and remote users via a remote web server.

Key-Words: WSN, Internet-of-Things, Carbon dioxide, Carbon monoxide, Carbonyls, Indoor air quality monitoring, Nitrogen dioxide, Volatile organic compounds.

1 Introduction

The Internet-of-Things (IoT) has become very attractive in the modern wireless communications context. IoT implies “*a worldwide network of interconnected objects uniquely addressable, based on standard communication protocols*” [2]. Basically, the main idea of the IoT is the distribution of ubiquitous “objects” or “things”, which collect and exchange data in order to reach a common objective by means of mutual interactions [1]. Recent advances of IoT technologies are spurring the development of Smart systems to monitor the air quality. IoT represents the fact of extending internet into the real world relating everyday objects. Nowadays, item and devices are no longer disconnected from the virtual world, but can be accessed remotely through internet services.

In the Smart environment context, IoT might be used to address the air pollution problem, which has both social and economical relevance. Carbon dioxide, ground-level ozone and particulate matter might cause asthma and respiratory diseases. Monitoring the air quality in the vital areas is one of the most challenging goals of modern-day society. The fact of delivering pertinent data of the surrounding gases to remote users and institutions is a primary issue.

In [6], the authors present the implementation and

the test of a real time environmental monitoring system using wireless sensor networks, capable of measuring temperature and greenhouse gas concentration levels such as CO, CO₂ and CH₄ levels. [4] present Polluino, a system for monitoring the air pollution via Arduino and they developed a cloud-based platform that manages data coming from air quality sensors. A comparison between two cloud computing service models and between two IoT communication protocols is performed.

Figure 1 demonstrates the vision of the end-solution for the indoor air quality (IAQ) monitoring and assessment. In this research, we capitalize on the wide expertise of the collaborators in the area to develop a functional, scalable and reliable system for IAQ measurement. Although the work is related to IAQ monitoring and assessment of outdoor air quality (OAQ) in the vicinity of sample buildings to be used in the study is important and will be carried out. The reason for this is the evident impact of OAQ on IAQ.

In [9] the authors designed a new ZigBee network for IAQ monitoring system. They introduce an energy saving ZigBee WSN network with low latency and high throughput for the IAQ monitoring system.

[5], presented a wireless sensor network for IAQM. The system combines knowledge from lower

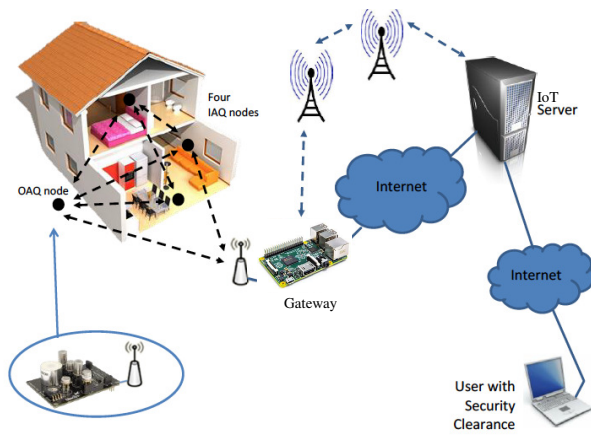

Figure 1: Architecture of the proposed system

levels (sensors) up to the network level exploiting multimodality of the network by adding the people presence sensing. The node lifetime they propose is much bigger than the biggest predicted lifetime in literature, which is 112 days in [3].

In [8], the authors present a study of indoor air quality (IAQ) in schools. The aims of their study are to evaluate indoor and outdoor concentrations of NO_2 , volatile organic compounds (VOCs) and carbonyls at 14 elementary schools in Lisbon, Portugal. The authors selected three schools to measure comfort parameters, such as temperature and relative humidity, CO_2 , CO, total VOCs and bacterial and fungal colony-forming units per cubic meter. Primary results show that indoor concentrations of CO_2 , in the three main schools, indicated inadequate classroom air exchange rates.

Poor air quality may cause increased short-term health problems such as fatigue and nausea as well as chronic respiratory diseases, heart disease, and lung cancer. According to the factors affecting the IAQ, and to the test items specified in the stadium hygiene inspection, the CO_2 concentration, temperature and humidity are tested as the objective items, respectively using the ZG106 CO_2 detector, the DT-8892 professional temperature and humidity tester. Meanwhile, the questionnaire is taken to the staff doing exercises in the gym as the subjective item, which is formulated according to the ASHRAE feeling scale.

Carbon monoxide (CO) is a colorless, odorless, tasteless, poisonous gas that is produced by the incomplete burning of various fuels, including coal, wood, charcoal, oil, kerosene, propane, and natural gas. Equipment powered by internal combustion engines such as cars, portable generators, lawn mowers, and power washers all produce carbon monoxide.

In this paper, we propose a novel IoT Smart architecture for air quality monitoring. Specifically, we

present a Smart global AQM system, which employs different, yet complementary, technologies, such as gas sensing, WSN and Smart mobile. Our proposed system, is able to collect, in real time and from different cities, data related to the concentrations of critical gases, humidity, and temperatures. Collected data are delivered to a local gateway where an advanced processing makes them easy and accessible by both, local and remote users via a remote web server at the IOT. The remainder of the paper is organised as follows. Section II, details the challenges of indoor air quality monitoring. An Integrated system for indoor AQM based on IOT is presented and discussed in Section III. An example of case study is shown in the result part of this paper in Section IV. Section V is dedicated to the conclusion of this paper.

2 Indoor Air Quality Monitoring Challenges

In this section, we present an overview of the indoor air quality monitoring and the challenges crossing the humanity to monitor the air quality and to avoid human and animal contaminations. According to [7], air pollution implies “*the presence in the earth’s atmosphere of one or more contaminants in sufficient quantity to cause short- or long-term deleterious effects to human, animal, or plant life, or the environment*”. These pollutants can be classified into primary pollutants which are released directly into the atmosphere from sources and have high health impact. Secondary pollutants are formed by chemical processes acting upon primary pollutants. The pollutants able to injure health, harm the environment and cause property damage are

- . Carbon monoxide (CO),
- . Lead (Pb),
- . Nitron dioxide (NO_2),
- . Particular Matter (PM),
- . Ozone (O_3),
- . Sulfure dioxide (SO_2),

Human CO_2 emissions pose a threat to public health and welfare. Legally in the USA, CO_2 is an air pollutant which must be regulated if it may endanger public health or welfare. Humans have increased the amount of CO_2 in the atmosphere by 40. When considering the legal definition of “air pollutants” and body of scientific evidence, it becomes clear that CO_2 meets the definition and poses a significant threat to public health and welfare.

Nowadays, air pollution inside buildings is a growing problem. As people spend 90% of the time inside the buildings (malls, institutions, offices and schools ...) indoor air quality is the most influential factor for health, safety and comfort. In the last few

years, some wireless sensor network based solutions for indoor air quality monitoring are developed. Sensor nodes, deployed inside the building, send data to the sink node by single hop or multi-hop communications. The sink node is the gateway which is able, via ZigBee link, to collect raw data from each sensor node.

3 An Integrated System for IAQM

Sensor nodes, deployed inside the building, send data to the sink node by single hop or multi-hop communications. The sink node is a gateway which is able, via ZigBee link, to collect raw data from each sensor node. In this section, we illustrate the acquisition system and the gateway we designed for indoor air quality monitoring. The acquisition board is based on Libelium Gas sensors pro equipped with ZigBee communication feature (Figure 2). However the gateway consists of the a Raspberry Pi 2 board.

3.1 Wireless Sensor Node :

The key hardware features are illustrated with the aid of the block diagram below.

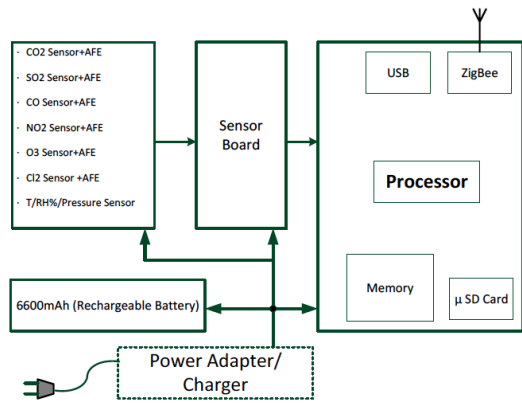

Figure 2: Block diagram of the Gas Sensor Node that we employ.

3.1.1 Choice of sensors :

Libelium has a large collection of gas sensors acquired from third party sensors manufacturers. The sensors available from Libelium are either non-calibrated or factory-calibrated. In this work, we decided to opt for pre-calibrated sensors for rapid deployment. Frequent re-calibration of these sensors will be done using a developed Test Bed. Libelium provides generic platforms capable of running, interfacing, and data collection from these sensors. The open platforms allow the

users to customize the gases they desire to monitor in their facilities.

The selected gas sensors operate either of electrochemical or Non Dispersive Infrared NDIR types; the specifications of these sensors are given in Table 1

Table 1: Specifications of the selected gas sensors.

Sensor name	Nominal Range (ppm)	Accuracy (ppm)	Response time (s)	Sensor Type	Auxiliary Electrode
Sulphur dioxide (SO2)	0 - 20	+/- 0.1	<= 45	Electrochemical	No
Nitrogen dioxide (NO2)	0 - 20	+/-0.1	<= 30	Electrochemical	No
Nitrogen oxide (NO)	0- 250	+/- 0.5	<= 30	Electrochemical	No
Carbon dioxide (CO2)	0 - 5000	25	60	NDIR	N/A
Carbon monoxide (CO)	0 - 1000	+/- 2	<= 30	Electrochemical	No
Chlorine (Cl2)	0 - 50	+/- 0.1	<= 30	Electrochemical	No
Ozone (O3)	0-0	+/-0.005	<=15	Electrochemical	Yes

3.1.2 Embedded hardware :

The Libelium board (Figure 3) that we employ provides an embedded solution named “Waspnote” which was chosen for the wireless sensor node. The choice was made for the following reasons :

1. Interfaces with Gases Pro Board: As mentioned before Gases Pro Board was chosen due to its ability to interface with six sensors. Gases Pro Board can be directly plugged to Waspnote thus proving hardware simplicity, compact design and reduced node size.
2. Compatible with Zigbee: The board features the hardware required to directly integrate the XBee transceiver thus providing a compact node hardware setup.
3. Compatible with a wide number of wireless network: Waspnote supports WiFi (IEEE 802.11), Zigbee (IEEE 802.11.4), Bluetooth and Lo-RaWAN, thus providing choices of network for the final node network.
4. On board storage facility with SD Card: This feature can be used to set up a backup store for the sensors to provide immunity against wireless link failure.
5. Extensive archive of S/W libraries: The libraries are shipped with the IDE available from Libelium for Waspnote which will facilitate quick, reliable and bug free firmware development.

3.1.3 Sensor node and communication features :

The sensor node has to incorporate a wireless network to communicate wirelessly with the gateway. Power requirement, distance and indoor through-wall communication were the two main factors which had to be considered while choosing the network for the node. Zigbee (IEEE 802.11.4) was chosen as the desired wireless network as it meets our requirements. Furthermore, Zigbee nodes can transmit data over long distances using a wireless mesh network configuration.

3.1.4 Firmware implementation of the sensor node :

The firmware operates the node in two modes which are i. Calibration mode and ii. Monitoring mode. By default the node stays in Monitoring mode. In order to change the operating mode the sensor node has to be operated in server-client architecture where the sensor node is the server. The client node (Gateway/PC of the calibration rig) can change the operating mode by sending specific commands to the server to which if possible it will acknowledge or otherwise not.

i. Monitoring Mode : During this mode, the node monitors the sensors, acquires reading, stores them in SD card and transmits to the gateway. The sequence of tasks entitled to the sensor node during this mode is illustrated with the aid of a flowchart shown in Figure 4. Note that the sensor readings are stored with timestamp initialized by the user, and based on the clock of the Wasp mote processor (Figure 2).

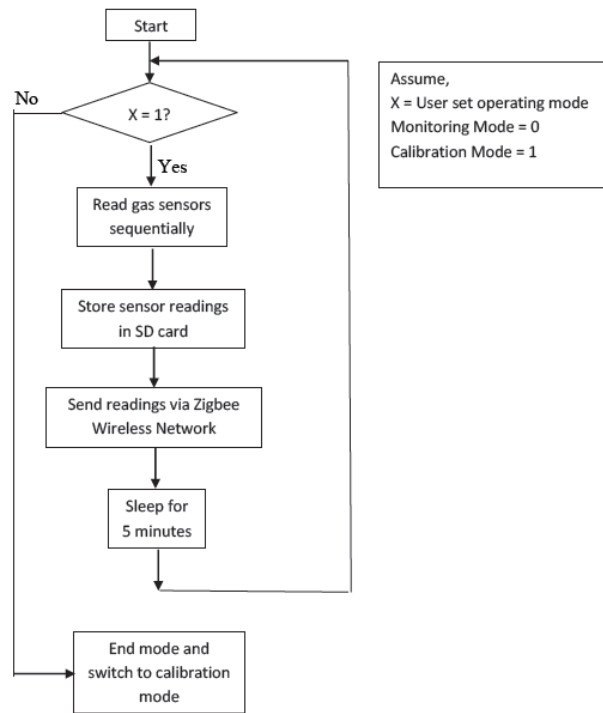
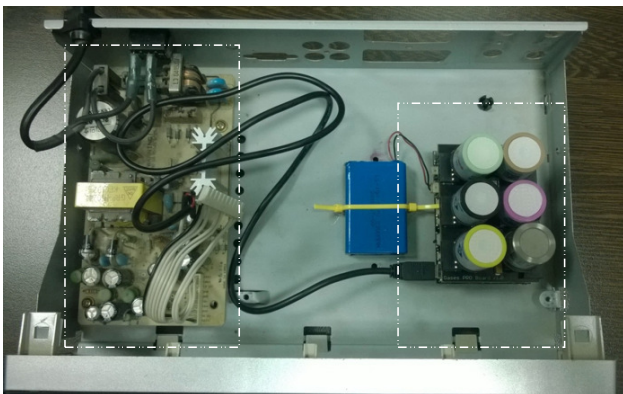

Figure 4: Flowchart for monitoring mode.

This is achieved using a client-server setup where the sensor node acts as the server and the calibration rig PC serves as a client. During the calibration process the client polls the sensor readings for various concentrations and temperatures. Once completed it transfer the calibration data file to the sensor node using FTP over Zigbee.



Mains to 5V DC Power Adapter

Libellium Sensor board

Figure 3: First prototype of the complete wireless sensor node.

ii. Calibration Mode : The sensor node is operated in this mode when it needs to be calibrated. The process of calibration involves uploading a calibration data file to the nodes SD card from the calibration rig.



Figure 5: Sample sensor data during monitoring Smart mode sent over Zigbee.

3.2 Gateway of the wireless sensor network for IAQM

3.2.1 Hardware setup :

In the following, we present the implementation details of Gateway employed in the wireless sensor network. The gateway consists of the Raspberry Pi 2 board. We selected this board since it is very compact and easy to configure and maintain. The Raspberry Pi is a credit card-sized computer that plugs into your TV and a keyboard. It is a capable little computer which can be used in electronics projects, and for many of the things that your desktop PC does, like spreadsheets, word processing, browsing the internet, and playing games. It also plays high-definition video. We want to see it being used by kids all over the world to learn programming. The low cost and the size of the Raspberry Pi make it very popular and requested in several real time applications. The setup and the configuration of one Raspberry Pi board is very easy since a micro SD is available with preinstalled OS and drivers. In addition Ubuntu/Linux users can easily install and configure applications from binary and sources. All these features are not available with other embedded boards which are very specific and difficult to prepare and build the OS and the cross compilers. The Raspberry Pi 2 is the second generation Raspberry Pi its features include:

- A 900MHz quad-core ARM Cortex-A7 CPU
- 1GB RAM
- 4 USB ports,
- Full HDMI port,
- Combined 3.5mm audio jack and composite video
- 40 GPIO pins,
- Ethernet port,
- Camera interface (CSI),
- Display interface (DSI),
- Micro SD card slot,

3.2.2 Posting data to the Internet of Things platform :

Actually, engineers and researchers of different domains have several available Internet of Things platforms. The IoT used for our AQM application is the Emoncms which is a powerful open-source web application for processing, logging and visualising energy, temperature and other environmental data from the open-source energy monitoring project OpenEnergyMonitor.org. We adapted Emoncms web application to our system since it is flexible and provide the storage of data for a long duration from hours to years. Our first step of managing the IoT is from the OpenEnergyMonitor system. This later has the capability of monitoring electrical energy use/generation, temperature and humidity.

Using the IoT platform, we propose a Smart IAQM monitoring system for online users. It con-

sists of an intelligent air monitoring system that would enable people in the production facility stay notified about air quality.

A fine control of the AQM data is available by the extended web interface of EmonCMS that is shown in Figure 6. However this interface is hidden to the final user from Personal Computer or from Smart phone. In addition, by the GUI the user can also set the constraints about the utilisation of his appliances such as the earliest and the latest start time. The dashboard illustrating the data in graphs with several methods are also configured and set up using the GUI.

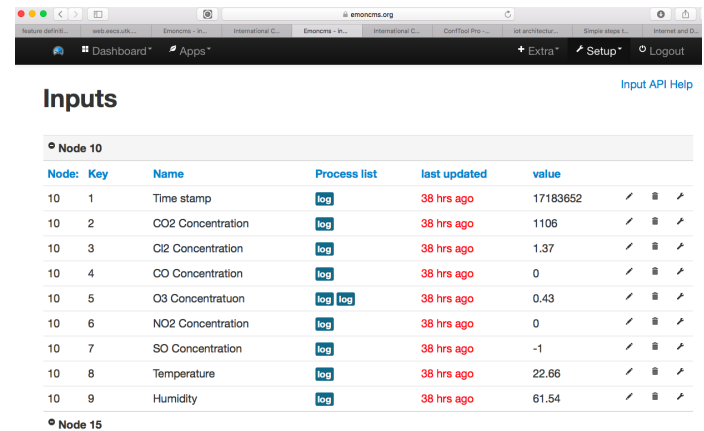

Node	Key	Name	Process list	last updated	value			
10	1	Time stamp	log	38 hrs ago	17183652	/	■	/
10	2	CO2 Concentration	log	38 hrs ago	1106	/	■	/
10	3	Cl2 Concentration	log	38 hrs ago	1.37	/	■	/
10	4	CO Concentration	log	38 hrs ago	0	/	■	/
10	5	O3 Concentratuon	log log	38 hrs ago	0.43	/	■	/
10	6	NO2 Concentration	log	38 hrs ago	0	/	■	/
10	7	SO Concentration	log	38 hrs ago	-1	/	■	/
10	8	Temperature	log	38 hrs ago	22.66	/	■	/
10	9	Humidity	log	38 hrs ago	61.54	/	■	/

Figure 6: EmonCMS input view.

3.2.3 Software setup of the Gateway

Because Raspberry Pi 2 has an ARMv7 processor, it can run the full range of ARM GNU/Linux distributions, including Snappy Ubuntu Core, as well as Microsoft Windows 10.

On the gateway based on linux operating system, a script is running continuously and it is able to :

- Collect data from all the Libellium Gas sensor boards via Xbee Link.
- Analyse the received data, and in worst cases apply a local calibration based on a lookup table stored at the gateway.
- Post the data to the IoT plate form using the specific APIs and the required APIkeys.
- Store the collected data in a local data base or in a files to be used for backup during internet disconnection.
- Detect the case of failure when the system meet a disconnection on the internet link. In that case a backup process is called and it performs the post of missed data to the IoT using past timestamps.

All the scripts are coded in Python and PHP and in each instant we post data by creating an array of fields in csv format containing the identity of the node, a timestamp (required for posting past data), the ApiKeys and field1, field2,... filedN where all these fields are in string format.

4 Measurement results

The aim of this part is to evaluate the air quality in a school. In the following, we will focus our effort on the evaluation of the air quality such as carbon dioxide CO₂, carbon monoxide CO, chlorine Cl₂, ozone O₃, the temperature, humidity and some other gases.

Continuous air quality monitoring was proceed in a secondary school in Doha (QATAR) during the period from June 13, 2016 to June 23, 2016. The school is open for staff from 6:30 and for the students from 7:00 am to 2:00 pm. The students have two breaks, at 10:30 am and at 12:00 pm. The official non working days for schools in Qatar are Friday June 17 and Saturday June 18. In addition, the working time is a non-stop duration from 7:30 am to 2:30 pm.

Figure 7 depicts the measurement results. The CO₂ concentration increases with the increase of occupancy. Thus, during the week-end, from Friday to Saturday, the school is empty, and then the CO₂ level drops. However, on Saturday, there exists a small increase on CO₂ concentration between 08:00 am to 17:00 am which corresponds to the cleaning activity during which cleaners are on duty.

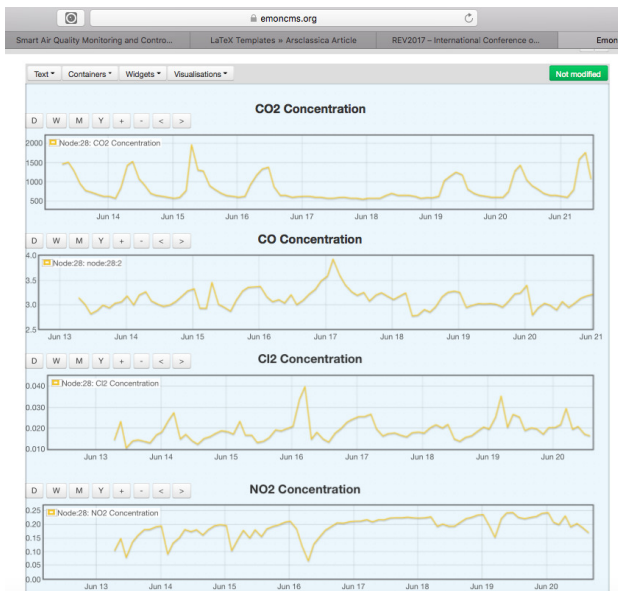

Figure 7: Indoor air quality data as displayed by the IOT, Emoncms web-application.

During the working days, where the students

are in school, the CO₂ concentration increases and reaches a maximum between 1500 and 2000 ppm at 08:30 am and at 12:30 pm, respectively. The CO₂ concentration starts its decrease at 2:00 pm and reaches the minimum close to 5:50 ppm. This slow decrease is due to the fact that the ventilation system requires time to flash out existing CO₂-rich air. The school employs split air conditioners. Indeed, split air conditioning, simply cools the air without ventilation.

Figure 7 depicts also results of CO measurements during the nine days. For each day, the carbon monoxide concentration shows a level increase from 4:00 pm to 03:00am (next day). According to the trends in the temperature and carbon monoxide curves, we can notice that the CO concentration is relatively correlated to temperature.

In urban outdoor air, the presence of NO₂ is mainly due to traffic. Nitric oxide (NO), which is emitted by motor vehicles or other combustion processes, combines with oxygen in the atmosphere, producing NO₂. Indoor NO₂ is produced mainly by un-vented heaters and gas stoves. NO₂ is also precursors for a number of harmful secondary air pollutants such as ozone and particulate matter. Exposure to NO₂ may affect health independently of any effects of other pollutants. However, because its presence is closely linked to the formation or presence of other air pollutants, it is difficult to establish the health effects attributable to NO₂ alone. Figure 7 depicts the NO₂ levels during the measurement campaign.

Measurements of Chlorine (Cl₂) concentration indicate minimum and maximum levels, at 04:00 pm and 03:00 am respectively.

During the nine days, we derived the measurements of the Chlorine (Cl₂) concentration at the school (Figure 7). There exist also relative minimum and maximum respectively at the instant 04:00 pm and 03:00 am Figure 7.

5 Conclusion

In this paper, we review the ongoing research within air quality monitoring systems in terms of wireless communication infrastructure, system architecture and IoT platform issues. We perform the analysis of the main challenges in term of communication technologies and data acquisition. A wireless sensor network has been designed and implemented for the measurement of indoor air quality. The sensor nodes are fitted with sensors for measuring carbon dioxide, carbon monoxide, Chlorine and Nitric dioxide in addition to temperature and humidity. A data collection

campaign in a typical school in Doha Qatar, has been organised using the developed platform. All the collected data are posted by the proposed platforms to an IoT, to make them well displayed and available for users from anywhere. Results indicate overall compliance with international standards. .

Acknowledgements

This publication was made possible by the support of NPRP grant NPRP 6 - 600 - 2 - 250 from the Qatar National Research Fund (a member of Qatar Foundation). The statements made herein are solely the responsibility of the authors.

References:

- [1] Luigi Atzori, Antonio Iera, and Giacomo Morabito. The internet of things: A survey. *Computer networks*, 54(15):2787–2805, 2010.
- [2] Debasis Bandyopadhyay and Jaydip Sen. Internet of things: Applications and challenges in technology and standardization. *Wireless Personal Communications*, 58(1):49–69, 2011.
- [3] Saverio De Vito, Paola Di Palma, Carmine Ambrosino, Ettore Massera, Gianbattista Burrasca, Maria L Miglietta, and Girolamo Di Francia. Wireless sensor networks for distributed chemical sensing: Addressing power consumption limits with on-board intelligence. *IEEE Sensors journal*, 11(4):947–955, 2011.
- [4] G. B. Fioccola, R. Sommese, I. Tufano, R. Canonico, and G. Ventre. Polluino: An efficient cloud-based management of IoT devices for air quality monitoring. In *2016 IEEE 2nd International Forum on Research and Technologies for Society and Industry Leveraging a better tomorrow (RTSI)*, pages 1–6, Sept 2016.
- [5] Vana Jelacic, Michele Magno, Davide Brunelli, Giacomo Paci, and Luca Benini. Context-adaptive multimodal wireless sensor network for energy-efficient gas monitoring. *IEEE Sensors Journal*, 13(1):328–338, 2013.
- [6] Ashenafi Lambebo and Sasan Haghani. A wireless sensor network for Environmental Monitoring of Greenhouse Gases. In *Proceedings of the ASEE Zone I Conference*, pages 1–4, 2014.
- [7] Dean E Painter et al. Air pollution technology. 1974.
- [8] PN Pegas, CA Alves, MG Evtugina, T Nunes, M Cerqueira, M Franchi, CA Pio, SM Almeida, and MC Freitas. Indoor air quality in elementary schools of lisbon in spring. *Environmental Geochemistry and Health*, 33(5):455–468, 2011.
- [9] Kim Fung Tsang, Hao Ran Chi, Luxiang Fu, Lili Pan, and Hiu Fai Chan. Energy-saving IAQ monitoring ZigBee network using VIKOR decision making method. In *2016 IEEE International Conference on Industrial Technology (ICIT)*, pages 2004–2009. IEEE, 2016.