

# Linearization Techniques to Overcome Nonlinear Effects of RF Power Amplifier in Mobile Communication

<sup>1</sup>PUNEETH S., <sup>2</sup>RANGARAJU H. G.

<sup>1</sup>Department of Electronics and Communication Engineering, KSSEM, Bengaluru

<sup>2</sup>Department of Electronics and Communication Engineering, Govt. SKSJTI, Bengaluru

**Abstract:** Power amplifier (PA) is the basic block of an RF communication system. PA is traditionally a non-linear device, but any increase in spectral efficiency demands the use of a linear power amplifier in mobile communications. The design of such power amplifiers with a constant envelope is a critical issue. Linearization techniques help in improving the performance by reducing the nonlinear effects of the power amplifier. This paper explains complexity, bandwidth and power added efficiency of different techniques of linearization, which can be used to increase the PA performance by mitigating the non-linear effects.

**Key-Words:** Power Amplifier, Linearization Techniques and RF Communication

## 1. Introduction

An efficient power amplifier helps in the development of lightweight microsatellites for communications, high data rate cellular phones, a collision-avoidance radar system for cars, at a lower cost. These can be achieved by developing linear Power amplifiers to transmit signals. The phone's silicon-based technology i.e, CMOS cannot be integrated with cell phone amplifiers, since they are made of gallium arsenide. The CMOS-based power amplifier design allows researchers to integrate the power amplifier and phone's electronic chip which reduces power consumption and manufacturing costs.

The fifth-generation wireless systems use multiple Gbps of data rates. Such high data rate systems require multiple power amplifiers and beamforming transceiver architectures. Another challenge lies in the design of a PA with high peak to average power ratio of digitally modulated signals.

In an RF transmitter, the power amplifier transmits a modulated signal to the antenna with the necessary power levels to the receiver. The performance of power amplifiers in different semiconductor technologies are measured as output power level, power added efficiency and linearity.

Hence, the design specifications of the power amplifier depend on the modulated signal because there is a trade-off between linearity and efficiency.

## 2. Power Amplifier

Power amplifier [1] as shown in Figure.1 is powered by a power source  $V_g$  with output impedance  $Z_s$ . The load  $Z_l$  is connected to the output.  $Z_{in}$  and  $Z_{out}$  are the input and output impedances respectively.  $P_{in}$  and  $P_{out}$  are the input and output power respectively.  $P_g$  is the power from the source and  $P_L$  is the power delivered to the load.  $P_{DC}$  is the input DC power and  $P_{ds}$  is the dissipated power from the amplifier.

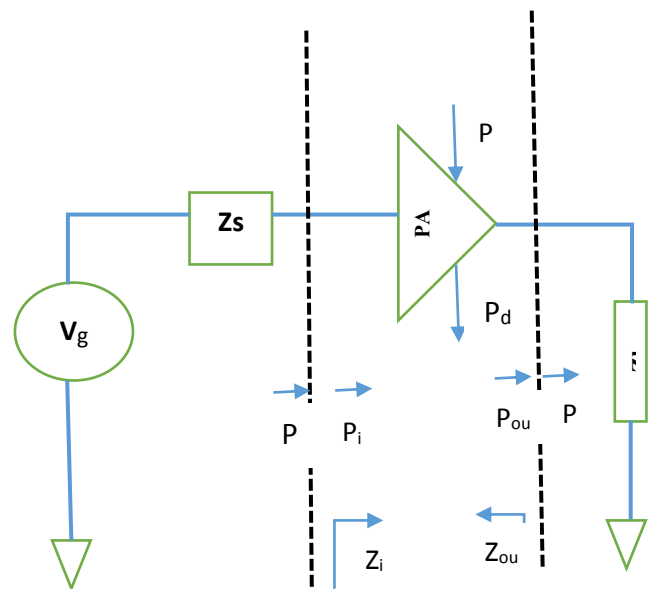

**Figure 1: Power Amplifier**

Considering impedance matching between the input and output and no power reflection,  $P_g = P_{in}$ , and  $P_{out} = P_L$  is desired. Hence the power gain [2] is defined as

$$G = \frac{P_{out}}{P_{in}}$$

Efficiency [2] of a power amplifier is classified as **Drain Efficiency ( $\eta$ )**. It is the ratio of the DC power to RF power.

$$\eta = \frac{P_L}{P_{DC}}$$

**Power Added Efficiency (PAE):** It is the ratio of the DC power to RF power, along with the power needed to drive the amplifier. If lower input power generates the same output power, the power gain is large and PAE is equal to drain efficiency.

$$PAE = \frac{P_{out} - P_{in}}{P_{DC}} = \eta \left(1 - \frac{1}{G}\right)$$

RF power amplifier amplifies the input signal to a suitable level of power and transmits the same to the receiver in free space. Wireless communication systems have a common transmission channel, and the available spectrum bandwidth is narrow. The signals transmitted are sensitive to disturbances such as nonlinear amplification, resulting in a distortion of the output signal and expands to other adjacent channels which degrade the performance of the system. Thus power amplifier should operate linearly.

Linearity and efficiency are two main parameters in the design of a power amplifier but most of the linear amplifier is not efficient. There are two broad categories of Power amplifiers [3].

**Sinusoidal:** Here the controlled current source is used as an active device. Sinusoidal power amplifiers shown in figure 2 are designed using a common source amplifier with an inductive load and an output matching network. Change in the bias voltage of source  $V_{in}$  changes the class of operation. Classes A, AB, B, and C are sinusoidal class power amplifier.

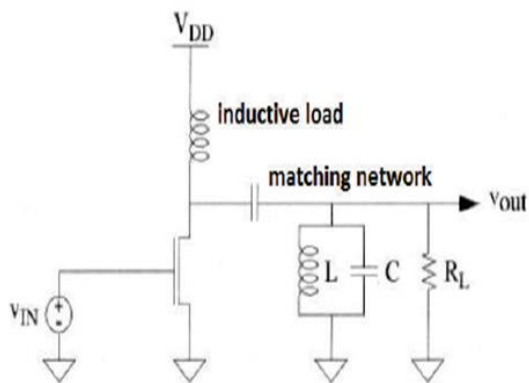

Figure 2: Sinusoidal Power amplifier

**Switched:** Here switch is used as an active device and transistor acts as a switch instead of a current source. The efficiency is ideally 100%. Class D, E and F are switched class power amplifiers. For GHz-range applications, class-D is rarely used. Class F requires a large size for integration. Hence the class-E amplifier is used practically

### 3. Linearization Techniques

Distortions due to the nonlinearity of power amplifiers can be minimized using several linearization techniques. They are Back off, Linear Amplification with Nonlinear Components (LINC), Feedforward, Feedback and Predistortion (PD) Method.

#### 3.1 Back off Linearization Technique

In wireless communication systems, by operating a power amplifier with the suitable back off from its saturation point, linear amplification can be achieved. Here, the maximum power level of input is restricted to make the entire signal to be present in the linear region of the power amplifier [4] [5]. Though it is not exactly a linearization technique, it can be realized and adopted in practical application, and even has lower power efficiency. This does not apply to nonlinear classes C and D power amplifiers, and should be avoided for millimetre wave applications.

#### 3.2 Linear Amplification using Nonlinear Components (LINC) Linearization Technique

Here, the input modulated RF signal is divided into two signals: constant-envelope and phase-modulated RF signals. Then, these signals are separately amplified by two PAs with the same characteristics and two outputs are summed up with minimal distortions at the output, as shown in figure 3.

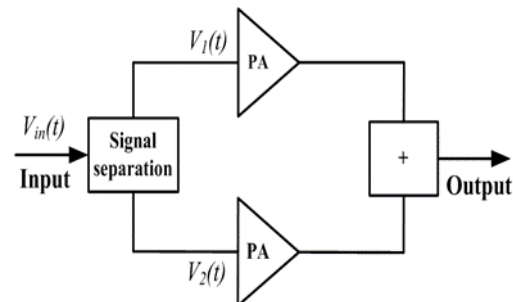

Figure 3: Linear amplification using Nonlinear Components (LINC)

This technique is applied to high efficient class C, D or E nonlinear PAs. This method can be used in the nonlinear high efficiency power amplifier. This technique is highly sensitive to gain and phase variation between the two PA branches. At RF level, signal separation becomes complex and a combination of signals from the two PA branches is difficult.

### 3.3 Feed forward Linearization Technique

This technique subtracts the harmonic and intermodulation distortions from the amplifier output as shown in figure 4 and eliminates the distortions at the output of the power amplifier. The advantages of this technique is high stability at increasing prices. The feedforward technique gives good potential in wideband linearization. But the circuit complexity and cost increase with respect to other techniques [6] [7].

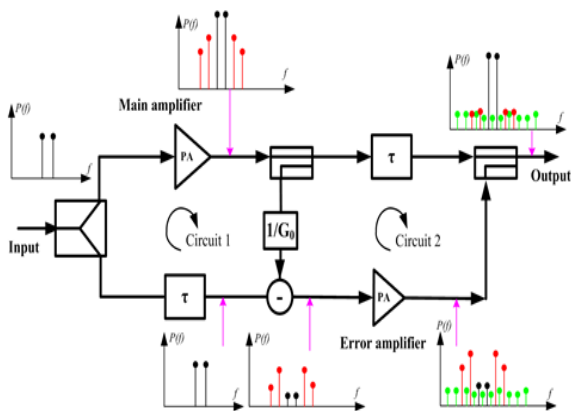

Figure 4: Feedforward Technique

### 3.4 Feedback Linearization Technique

To enhance the system performance, a feedback mechanism is used. This technique is used to linearize the power amplifier of narrowband systems as shown in figure 5. Here, the nonlinear PA output is applied to a divider ( $\beta$  factor) and the divided output is then combined with the input of the PA. Polar feedback loops and Cartesian feedback loops constitute input correction or predistortion (PD) methods [8]. Their Advantage lies in the low complexity. The disadvantage is that the input signal cannot be operated at the same instant as output signal due to the delays in the circuits. Stability of the system restricts the bandwidth to a few hundred kHz and ensure that it cannot be used in wideband systems [9].

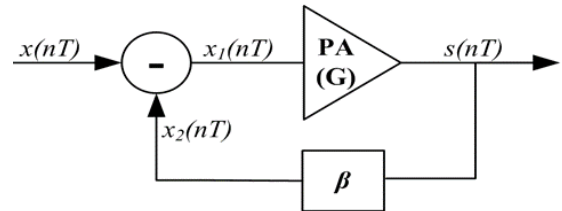

Figure 5: Feedback Technique

### 3.5 Predistortion Linearization Technique

Compared to the distortion products, this method generates signal components proportional to the inverted amplitude and opposite phase such that a linearized characteristic can be achieved [10]. In Predistortion (PD) technique predistortion circuit is placed before the PA as shown in figure 6, which inverts the nonlinear characteristic of the PA and gives rise to a new predistorted input for the nonlinear PA. Advantage of this technique is that knowledge of physical circuit of the power amplifier is not required, and is highly flexible and reconfigurable.

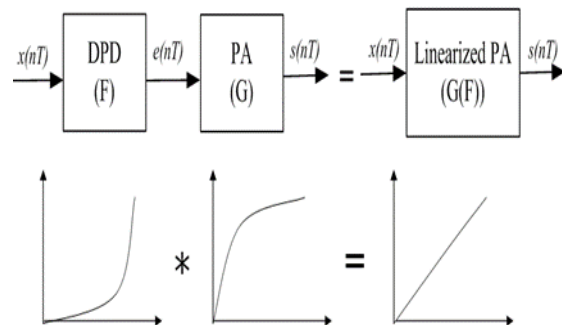

Figure 6: Predistortion Technique

These techniques are summarized below in the table 1, with respect to the complexity involved in design, bandwidth and power efficiency

Table 1: Comparison of different techniques

Linearization Technique	Complexity	Bandwidth	Power Efficiency
Back off	Design complexity is low	Narrow Bandwidth of 15 to 20MHz	Low
LINC	Design complexity is high since	Narrow Bandwidth of 15 to	High

	separation and combining signals is difficult	20MHz	
Feedforward	Design complexity is high because it subtracts harmonic and intermodulation distortions from amplifier	Wide Bandwidth of 25 to 65MHz	High
Feedback	Design complexity is low	Narrow Bandwidth of 15 to 20MHz	Low
Predistortion	Design complexity is low	Wide Band	High

From the above table, it is clear that Predistortion technique has high power efficiency and reduced complexity in design for wideband systems. Several techniques have been put forward to increase the efficiency at the higher back off and circuit complexities, such as Doherty technique.

#### 4. Conclusion

Highly Efficient and linear power amplifier has been a major research issue in developing the wireless application. The predistortion technique is easy to realize, flexible, offers a high degree of linearization, high integrability, no stability problem and is reconfigurable with respect to the other techniques.

#### 5. References

[1] N. Deltimple, "Etude et réalisation d'un amplificateur de puissance reconfigurable en technologie BiCMOS SiGe pour des applications multi-standards GSM / DCS / UMTS," 2005.

[2] M. A and G. F. M., "RF power amplifier and linearization techniques," *RF Transceiver Design for MIMO Wireless*

*Communications*, pp. 77–128, 2012.

[3] Steve C Cripps, Book-"Advanced Techniques in RF Power Amplifier Design," 2002.

[4] V H DO, V Subramanian, W. Keusgen and G Boeck, "A 60GHz Si-Ge HBT Power Amplifier with 20% PAE and 15dBm Output Power," *IEEE Microwave and Wireless Components Letters*, vol. 18, pp. 209-211, 2008.

[5] P. Colantonio, F Giannini and E Limiti, Book-"High Efficiency RF and Microwave Solid State Power Amplifiers," 2009.

[6] P. B. Kenington, Book-"High Linearity RF Amplifier Design," 2000.

[7] H Ishihara, M Hosoya, S Otaka and O Watanabe, "A 10MHz Signal Bandwidth Catesian Loop Transmitter Capable of Off Chip PA Linearization Technique," *IEEE Journal Solid State Circuits*, Vols. 45, no.12, pp. 2785-2793, 2010.

[8] Steve C. Cripps., Book-"RF power amplifiers for wireless communications.," 1996.

[9] L. W. J. P. H. S. J. X. C. D. I. M. Roblin P, "Poly-Harmonic Modeling and Predistortion Linearization for Software-Defined Radio Up Converters," *IEEE Transactions on Microwave Theory and Techniques*, p. 2125–2133, 2010.

[10] V. J. M. J. Rahkonen T, "Measurement Technique for Characterizing Memory Effects in RF Power Amplifiers," in *IEEE Radio and Wireless Conference*, 2000.