

# Research on 2D Direction Finding System of Phase Interferometer based on multi-antenna

YUANPING SHI, HONGXIA JIA, PENGCHENG ZHAO

Department of Physics and Electromechanical, Shijiazhuang College, Hebei, 050035, China

*Abstract:* - In the radio direction finding system, direction finding methods of Phase Interferometer have been widely applied, but because of its direction finding ambiguity, there is a contradiction between direction finding range and direction finding accuracy. In order to relieve the contradiction, multi-baseline phase interferometer is generally used to measure angles. However, this method is mainly aimed at one-dimensional angle measurement, so its system utilization is low. Therefore, a phase interferometer based on multiple antennas is proposed in this paper to measure the angle of pitch and azimuth in two dimensions, and the dual-baseline ambiguity resolution method is used to improve the accuracy of pitching angle measurement. Finally, the simulation results indicated that the theoretical analysis was correct.

*Key-Words:* - Radio direction finding, Angle measurement, Phase Interferometer, Multi-antenna, Dual-baseline ambiguity resolution, Azimuth and pitching angle

## 1 Introduction

Radio direction-finding technology has a very significant position in many fields, such as radar navigation, sonar, mobile communication, geophysical prospecting and other direction-finding technologies[1-8]. Especially in electronic countermeasures, timely and accurate object positioning has always been a subject that people are actively studying[9-13]. Generally, the direction finding system can be divided into three categories: amplitude system, phase system and magnitude-phase combined system[14-16], of which the phase system is widely used at present, such as interferometer, Doppler and Watson-Watt[17-19]. As a direction finding method with high measurement accuracy, phase interferometer has the advantages of short data processing time and mature technology, so it is extensively used in the direction finding and location of radiation sources[20-24].

The discriminator can only measure the phase value within  $2\pi$  range because it usually takes  $2\pi$  as the module. If the relative phase exceeds  $2\pi$  among the antennas, the discriminator will produce multi-value ambiguity[25-27]. Due to the contradiction between the direction finding accuracy and range, the combination method of long and short baseline is adopted to solve the contradiction in the phase interferometer[28-32]. But the method requires that the short baseline length should be less than half wavelength in the traditional algorithm of long and short baseline combining. For high frequency signal, the antenna array element must be very small. So, this method will reduce the antennas gain and cause

antennas mutual coupling. And the existing phase interferometer can only measure the single direction angle (such as the azimuth or the pitching angle).

To solve this problem, a two-dimension direction finding system of phase interferometer based on multiple antenna is proposed in this paper. First, a dual-baseline ambiguity resolution algorithm is proposed to realize pitch angle measurement without limiting the minimum baseline length to less than a half wavelength, which is more practical; Second, the phase interferometer tracking angle measurement method is used to measure the azimuth angle simultaneously. The structure of paper is as follows: In section II, we introduce the angle measurement principle of 1-D phase interferometer. In section III, we propose the direction finding system model of 2D phase interferometer. In section IV, we present the realization scheme of 2D direction finding system based on multi-antenna. In section V, we discuss the principle of the algorithm in detail, and analysis the measurement accuracy of the ambiguity resolution algorithm and the influence of the angle measurement error under the noise circumstance. In section VI, we simulate the correctness of the theoretical analysis. Conclusions are drawn in section VII.

## 2 Angle Measurement Principle of 1-D Phase Interferometer

The angle measurement essence of interferometer is to determine the direction of the radiation source, which utilizes the phase difference

formed on the receiving antenna[33, 34]. It is shown as figure 1.

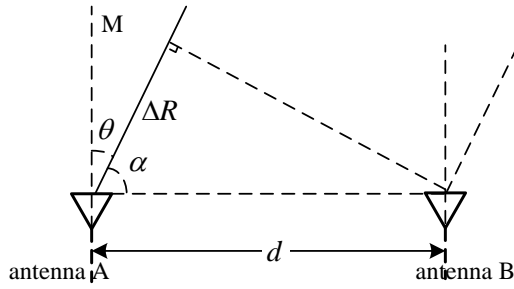

**Figure 1.** Schematic of interferometer angle measurement

Assuming that the baseline length between the receiving antennas A and B of the ground angle measuring system is  $d$ , the oblique distance of the far field angle measuring target from the ground is  $R$ , and the AM angle of the target deviating from the normal direction of the baseline is  $K$ , when the target is far from the ground and has  $R \gg d$ , the electromagnetic waves reaching antennas A and B can be considered as plane waves, then the phase difference of far-field target carrier signal received by antennas A and B can be expressed as:

$$\Delta\phi = \frac{2\pi d}{\lambda} \cos \alpha = \frac{2\pi d}{\lambda} \sin \theta \tag{1}$$

Where,  $\lambda$  is the wavelength.

However, if  $d > 0.5\lambda$ , the phase difference  $\Delta\phi$  may exceed the interval of  $(-\pi \pi)$ . Then the ambiguity of phase difference measurement is produced (the phase difference measuring equipment usually takes  $2\pi$  as the module, which is the measuring interval of  $(-\pi \pi)$ ). However, the longer the baseline, the higher the accuracy of direction finding. The proof is as follows:

The influence of the angle measurement component error is analyzed by the total differential of the angle measurement component of equation (1).

$$\delta_{\theta}^2 = \left( \frac{\lambda}{2\pi d \cos \theta} \right)^2 \delta_{\Delta\phi}^2 \tag{2}$$

Where,  $\delta_{\theta}$  is the measurement standard deviation of the direction angle  $\theta$ ;  $\delta_{\Delta\phi}$  is the standard deviation of the phase difference  $\Delta\phi$  measured by the receiver, which is usually caused by the data processing (such as quantization) noise, the uncoordinated phase between two channels and the thermal noise. Data processing noise is usually the main source in the whole measuring deviation. So, it is necessary to design a suitable processing circuit according to the system requirements; the

uncoordinated phase between two channels can be reduced by using appropriate correction (such as the two channels produce a fixed frequency difference). The phase standard deviation of single channel generated by thermal noise is related to the IF signal-to-noise ratio  $SNR$ , which is shown as follows:

$$\delta_{\Delta\phi}^2 = (2SNR)^{-1} \tag{3}$$

The phase standard deviation of two channels caused by thermal noise is  $\sqrt{2}$  times of  $\delta_{\Delta\phi}^2$ .

Assuming that the two-channel equipment is reasonably designed and that the phase standard deviation caused by the data processing noise and the channel incompatibility is small enough, the influence of thermal noise is primarily considered.

### 3 Direction Finding System of 2D Phase Interferometer

#### 3.1. System structure

According to the angle measurement principle of 1-D phase interferometer, the principle is mainly aimed at the angle measurement of single direction. If the baseline AB is horizontal direction, the azimuth angle can be measured. so is the pitch angle measurement. The following architecture is 2D direction finding system based on multi-antenna, which can measure the azimuth and elevation angle simultaneously. The 2D angle measurement structure based on multi-antenna layout is shown as figure 2. In the structure, four antennas (coded as A, B, C, D) are set on the same vertical plane. Antenna A and B are fixed on the same horizontal antenna pedestal. The midpoint of connecting line (coded as baseline AB) of the antenna A and B is used as the driving axis of azimuth angle measured by the interferometer. Through the servo system, the horizontal axis baseline AB can be controlled to rotate  $360^\circ$  around the midpoint. Then the azimuth angle of the target can be tracked and measured. The baseline of antenna C and A is perpendicular to the baseline AB, the baseline of antenna D and B is parallel to the baseline AC and perpendicular to the baseline AB. The length of the baseline AC is longer than that of the baseline BD.

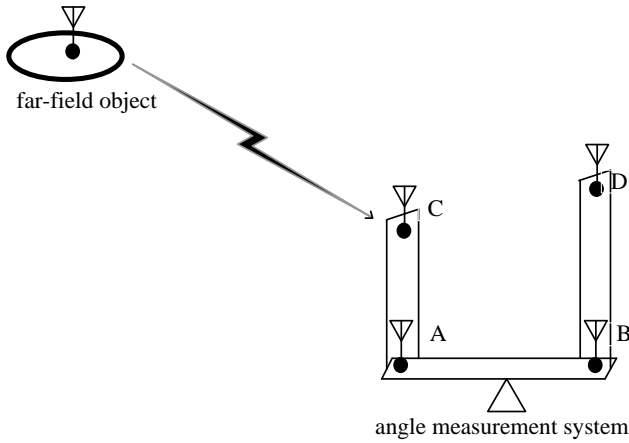

**Figure 2.** Sketch map of 2D angle measurement structure

According to the layout of angle measuring antennas, antenna A and B are used to measure the azimuth angle; antennas A, C and antennas B, D are used to measure the pitch angle.

### 3.2. Phase interferometer tracking azimuth angle measurement

The principle of phase interferometer tracking azimuth angle measurement is as follows: If the direction of normal AM deviates from the target (that is  $\theta \neq 0^\circ$ ), then the carrier phase difference will be  $\Delta\phi \neq 0$ . The positive and negative values of the measured phase difference  $\Delta\phi$  to control the servo system, which drives the antenna to track the angle measurement target automatically. Then the angle  $\theta$  is kept near  $0^\circ$ . So, the value  $\Delta\phi$  will also be kept near by  $0^\circ$ . Right now, there will be no problem of carrier phase ambiguity. If the initial position of antenna axis AB is calibrated to  $0^\circ$  proactively, the target azimuth angle can be calculated. When the antenna tracks phase automatically, the target azimuth information can be obtained by the azimuth rotation angle of the antenna axis AB.

### 3.3. Phase interferometer tracking azimuth angle measurement

Antenna B and D are used as auxiliary antennas to measure the pitch angle. Although the measurement method of pitch angle belong to the phase system, the method is fixed angle measurement rather than tracking angle measurement. But there is phase ambiguity problem in the fixed angle measurement method possibly. Therefore, a dual-baseline is constructed by antennas A, C and B, D to solve the problem of angle ambiguity.

Assuming that the relationship between the baseline AC and BD is as follows:

$$\frac{d_1}{d_2} = \frac{k}{l} \quad (4)$$

Where,  $k$  and  $l$  are the coprime integers. The phase differences between the antenna pair AC and BD are as follows:

$$\begin{cases} \Delta\phi_1 = (2\pi d_1/\lambda)\sin\theta \\ \Delta\phi_2 = (2\pi d_2/\lambda)\sin\theta \end{cases} \quad (5)$$

Due to the possible phase ambiguity, the actual measured phase differences are  $\Delta\tilde{\phi}_1, \Delta\tilde{\phi}_2$  (where,  $\Delta\tilde{\phi}_1, \Delta\tilde{\phi}_2 \in (-\pi, \pi]$ ). The phase differences can be expressed as

$$\begin{cases} \Delta\hat{\phi}_1 = 2m\pi + \Delta\tilde{\phi}_1 + \Delta\hat{\phi}_1 \\ \Delta\hat{\phi}_2 = 2n\pi + \Delta\tilde{\phi}_2 + \Delta\hat{\phi}_2 \end{cases} \quad (6)$$

Where,  $\Delta\hat{\phi}_1$  and  $\Delta\hat{\phi}_2$  are the phase difference measurement errors of two antenna pairs.  $m$  and  $n$  are the fuzzy numbers of the phase difference, which are integers.  $m \in \left[-\text{INT}\left(\frac{d_1}{\lambda}\right)-1, \text{INT}\left(\frac{d_1}{\lambda}\right)+1\right]$ ,  $n \in \left[-\text{INT}\left(\frac{d_2}{\lambda}\right)-1, \text{INT}\left(\frac{d_2}{\lambda}\right)+1\right]$  (where,  $\text{INT}(\bullet)$  is the rounding operation).

According to the equation (4)-(6):

$$k(2n\pi + \Delta\tilde{\phi}_2 + \Delta\hat{\phi}_2) = l(2m\pi + \Delta\tilde{\phi}_1 + \Delta\hat{\phi}_1) \quad \downarrow$$

$$(kn - lm) + (k\Delta\tilde{\phi}_2 - l\Delta\tilde{\phi}_1)/2\pi = (l\Delta\hat{\phi}_1 - k\Delta\hat{\phi}_2)/2\pi \quad (7)$$

Where, Assuming that

$$\begin{cases} F(m, n) = (kn - lm) + (k\Delta\tilde{\phi}_2 - l\Delta\tilde{\phi}_1)/2\pi \\ G(m, n) = F(m, n) - (l\Delta\hat{\phi}_1 - k\Delta\hat{\phi}_2)/2\pi = 0 \end{cases} \quad (8)$$

If the fuzzy number pair  $m_1, n_1$  is chosen as the real fuzzy number pair, the difference of  $F$  value between the fuzzy number pair and the real fuzzy number pair is as follows:

$$\Delta F = F_1(m_1, n_1) - F(m, n) = k(n_1 - n) + l(m - m_1) \quad (9)$$

If  $\Delta F \neq 0$ , then  $G(m_1, n_1) \neq 0$ . Now the  $|G(m, n)|$  corresponding to the real fuzzy number pair increases  $|\Delta F|$ . If  $\Delta F = 0$ ,  $|G(m_1, n_1)|$  reach Minimum  $|G(m, n)| = 0$ . Because  $G(m, n)$  and  $F(m, n)$  are only differ from the error combination term of  $(l\Delta\hat{\phi}_1 - k\Delta\hat{\phi}_2)/2\pi$  and the magnitude of the term is independent of the fuzzy number pair. So, a

suitable fuzzy number pair  $m_1$  and  $n_1$  can make  $|G(m_1, n_1)|$  reach the minimum zero. Then  $|F(m_1, n_1)|$  reaches the minimum. In series, when  $\Delta F = 0$ ,  $|F(m_1, n_1)|$  reaches the minimum  $|F(m, n)|$ .

Because  $k$  and  $l$  are coprime integers, if  $n_1 = n$  and  $m_1 = m$ , then  $\Delta F = 0$ . That is the real fuzzy number pair  $m$  and  $n$  is chosen as the fuzzy number pair  $m_1$  and  $n_1$ ,  $|F(m_1, n_1)|$  will reaches the minimum  $|F(m, n)|$ . So, the fuzzy number pair  $m_1$  and  $n_1$  corresponding to the minimum  $|F(m_1, n_1)|$  is the real value of fuzzy number pair. Simultaneously, the fuzzy number pair  $m_1$  and  $n_1$  should meet the value range.

### 4 Implementation scheme

The findings and their implications should be discussed in the broadest context possible. Future research directions may also be highlighted. The implementation process of multi-antenna direction finding is shown in figure 3, and the specific implementation steps are as follows:

(1) The downlink signals received by the four antennas are processed by RF and mixed. Then the IF signals of each channel are obtained;

(2) Through the frequency shifter, two LO signals  $S_1$  and  $S_2$  with fixed frequency difference are obtained. Channel signals  $S_1$  are sent to antennas A and D for mixing with two IF signals, and channel signals  $S_2$  are sent to antennas B and C for mixing with two IF signals. Then, fixed frequency difference is maintained between antennas A and B, antennas A and C, and antennas B and D;

(3) In order to reduce the additional phase difference caused by different channels, the design of four channels should be consistent. Every two signals (A and B, A and C, B and D) are added and transmitted in the same channel to keep the phase difference of two signals unchanged;

(4) Then, the phase difference information of channels A, B is obtained by detector and phase discrimination. The information is converted into DC error voltage. The voltage is sent to the servo system, which drives the execution unit to rotate towards the direction of reducing the error. So, the normal always points to the target. The self-tracking azimuth measurement is realized;

(5) The phase difference information of AC and BD channel is obtained by phase discrimination. According to the dual baseline defuzzification

algorithm, the fuzzy number pairs are determined to get the real pitch angle information.

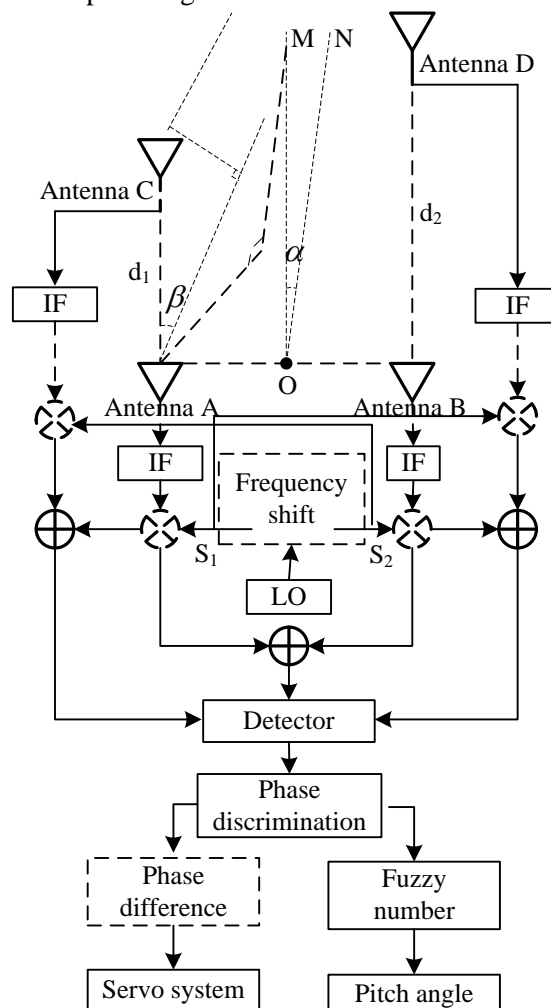

Figure 3. Realization flow of 2D angle measurement system

### 5 Accuracy analysis

For the defuzzification algorithm based on dual baseline, in order to solve defuzzification operation accurately, the requirement is:  $-0.5 < d_2 \Delta \hat{\phi}_1 - d_1 \Delta \hat{\phi}_2 / 2\pi < 0.5$ . According to the implementation scheme of angle measurement, the two channel pitch angles are sent to the same interferometer for measurement and calculation. Assuming that  $\sigma$  is the measurement error of the phase interferometer, then the mean square deviation of  $d_2 \Delta \hat{\phi}_1 - d_1 \Delta \hat{\phi}_2$  is  $\sigma \sqrt{d_1^2 + d_2^2}$ . And the measurement error should fall into the interval  $[-4\sigma \sqrt{d_1^2 + d_2^2} \quad 4\sigma \sqrt{d_1^2 + d_2^2}]$  with a probability of 99.9%. Therefore, in order to solve the fuzzy operation correctly, the following requirement is required:

$$4\sigma \sqrt{d_1^2 + d_2^2} < 0.5 \times 2\pi = \pi \tag{10}$$

However, for the traditional phase defuzzification algorithm of long and short baseline combining, it is usually required to  $|\rho\Delta\sigma_s - \Delta\sigma_l| < \pi$  (where,  $\rho$  is the length ratio of long baseline to short baseline,  $\Delta\sigma_s$  and  $\Delta\sigma_l$  are the phase measurement errors of short and long baseline respectively). Similarly, the combined measurement errors  $\rho\Delta\sigma_s - \Delta\sigma_l$  should fall into the interval  $[-4\hat{\sigma}\sqrt{\rho^2+1}, 4\hat{\sigma}\sqrt{\rho^2+1}]$  ( $\hat{\sigma}$  is the mean square error of long and short baselines used by the same channel) with a probability of 99.9%. In order to solve the phase defuzzification of long baseline phase interferometer accurately, the following requirement is required:

$$4\hat{\sigma}\sqrt{\rho^2+1} < \pi \tag{11}$$

Assuming that  $\rho = d_2/d_1$ , comparing the equation (10) and (11), if  $d_1 < 1$ , then  $\sqrt{d_1^2 + d_2^2} < \sqrt{\rho^2 + 1}$ , that is  $\sigma > \hat{\sigma}$ . So the measurement accuracy requirement of the multi-baseline angle measurement defuzzification algorithm is lower than that of the traditional defuzzification algorithm combining long baseline and short baseline; if  $d_1 > 1$ , the measurement accuracy requirement of the latter is lower. However, we usually set  $d_1 < 1$  in the traditional defuzzification algorithm. So the algorithm of multi-baseline angle measurement is easy to implement and popularize in engineering.

Now, we analysis the influence between the deviation of the pitch angle  $\theta$  and the phase measurement error in the equation (5). Defining  $S_1 = \sin \theta_1$  and  $S_2 = \sin \theta_2$ , then setting  $\Delta S = S_2 - S_1$ . The influence between pitch angle  $\theta$  deviation and phase measurement error can be analyzed through the total differential of  $\Delta S$ .

$$\delta_{\Delta S}^2 = \left( \frac{\lambda}{2\pi d_2} - \frac{\lambda}{2\pi d_1} \right)^2 \cdot \frac{1}{\text{SNR}} = \frac{\Delta d^2 \lambda^2}{4\pi^2 \text{SNR} d_1^2 (d_1 + \Delta d)^2} \tag{12}$$

Where,  $\Delta d = d_2 - d_1$  is the baseline difference.

### 6 Simulation analysis

Assuming that the frequency is 4.8Ghz, under the condition of  $\text{SNR} = -10\text{dB}$ , the influence of angle measurement accuracy causing by baseline length (in multiples of wavelength) and direction angle (the range is  $(-\pi/2, \pi/2)$ ) is shown as figure 4. In the figure, the influence of the direction finding standard deviation of the direction angle changes symmetrically which takes  $\theta = 0^\circ$  as axis.

And the direction finding standard deviation is the minimum at the position of  $\theta = 0^\circ$ . With the increase of the absolute value of  $\theta$ , the standard deviation of direction finding is also increasing. It also verifies that the angle measurement of phase interferometer has high angle measurement accuracy ( $\theta$  value is always in the range of  $0^\circ$ ). But in terms of baseline length, with the increase of baseline length, the smaller the standard deviation of direction finding is, the higher the accuracy of direction finding is.

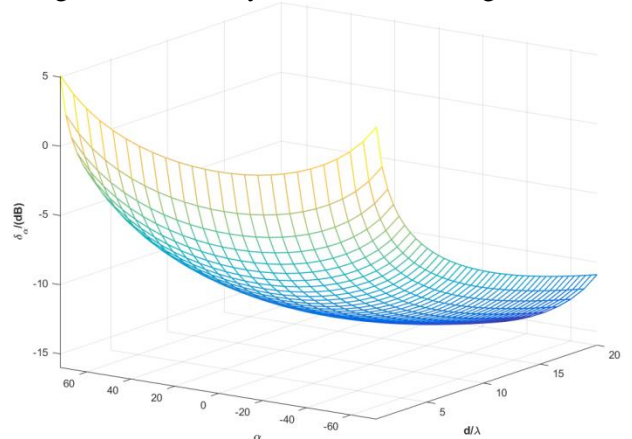

Figure 4. Influence of baseline and orientation angle on the angle measurement precision

When the baseline is determined, the unambiguous range of the measured direction angle is  $(-\theta_u, \theta_u) = (-\arcsin(\lambda/2d), \arcsin(\lambda/2d))$ . Figure 5 shows the relationship between the unambiguous direction angle range and the baseline. Where, the shaded part of the vertical line is the unambiguous direction angle range corresponding to the baseline length in the interval of  $0 \sim 10\lambda$ . The larger the baseline length is, the smaller the unambiguous bearing value is, and the smaller the corresponding unambiguous angle measurement range is.

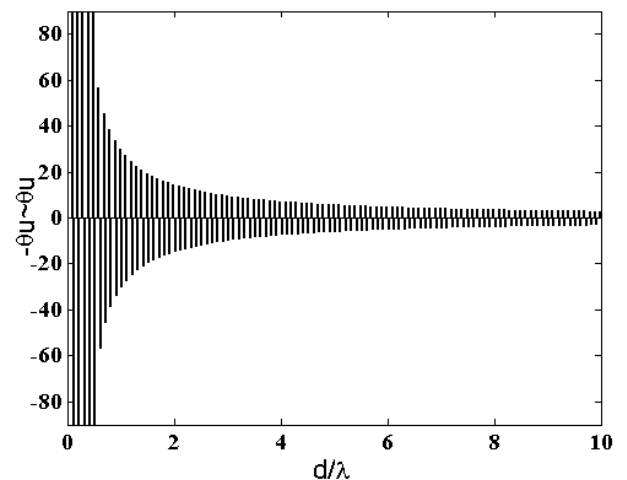
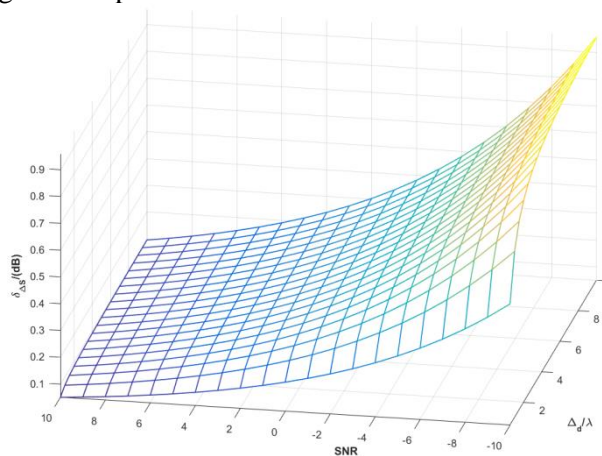

Figure 5. Relationships of baseline length and non ambiguity angle measurement range

Assuming that the frequency is constant, the short baseline length of the pitch angle measurement

is half wavelength. In the noisy environment, the relationship between the angle measurement error of the double baseline defuzzification and the signal-to-noise ratio and baseline difference is simulated, which is shown as Figure 6. With the increase of signal-to-noise ratio, the angle measurement error decreases gradually. When the signal-to-noise ratio is greater than 0dB, the angle measurement error is relatively small. With the gradual decrease of signal-to-noise ratio, the angle measurement error increases by 10% when the signal-to-noise ratio is reduced by every 2dB. While the angle measurement error changes little with the baseline difference by using the double baseline defuzzification method. The method is robust to the difference of long and short baseline, and is easy to design and implement.



**Figure 6.** Relationship among the angle measurement error, SNR and baseline difference

## 7 Conclusion

In this paper, we have presented a 2D angle measurement system of phase interferometer based on multiple antenna. The system can measure the azimuth and pitch angles simultaneously. The phase interferometer tracking azimuth angle measurement method can solve the phase ambiguity simply. The dual-baseline ambiguity resolution method is purposed to solve the phase ambiguity of pitching angle measurement, which can achieve high-accuracy. So, the system can be used in direction finding and positioning widely.

### References:

- [1] Q. R. Black, J. F. Wood, A. G. Sonstebly, et al. A direction finding ionosonde for ionospheric propagation research. *Radio Science*, 2016, 28(5):795-809.
- [2] S. A. Shaikh, A. M. Tonello. Complexity Reduced Direction Finding Massive MIMO System Using EM Lens. *Workshop on Dependable Wireless Communications and Localization for the IoT*. 2017.
- [3] H. P. Ladreiter, P. Zarka, A. Lecacheux, et al. Analysis of electromagnetic wave direction finding performed by spaceborne antennas using singular-value decomposition techniques. *Radio Science*, 2016, 30(6):1699-1712.
- [4] Sangjoon, Lee, Hyungoo, et al. Implementation of Real-Time Direction Finding System Using Time-Modulated Array with Two Antenna Elements and One USRP. *Journal of Korean Institute of Electromagnetic Engineering & Science*, 2017.
- [5] C. Rhrig, C. Kirsch, J. Lategahn, et al. Localization of Autonomous Mobile Robots in a Cellular Transport System. *Engineering Letters*, 2012, 20(2):148-158.
- [6] X. Li, D. W. Wu, T. L. Wei, et al. A radio navigation angle measurement method with entangled microwave signals. *AIP Advances*, 2018, 8(6).
- [7] Z. Haonan, W. U. Dewei, M. Qiang, et al. Navigation Ranging and Angle Measurement Scheme by the Power Divided Thermal Microwave Signals and Performance Analysis. *Journal of Air Force Engineering University(Natural ence Edition)*, 2019.
- [8] W. Zhang, Q. L. Huang, X. Chen. Autonomous celestial navigation method of asteroid probe based on angle measurement and velocity measurement. *Entia Sinica*, 2019.
- [9] D. Jiang, D.Z. Xie. Principle and Simulation of Single Satellite Frequency Difference Passive Location Technology. *Shipboard Electronic Countermeasure*, 2017.
- [10] H. Fuquan. Radio Location Method for Detecting Small and Medium Faults in Coal Mines Underground Measurement Research. *Acta Geologica Sinica(English edition)*, 2019, 93(z2).
- [11] S. Rong, D. U. Yu. Analysis on Equivalence between Tangential and Radial Motion Ranging Model for Single Observer Location. *Radio Engineering*, 2019.
- [12] L. Yong. Research on Laser Passive Reconnaissance and Location Technology. *Electro-Optic Technology Application*, 2018.
- [13] X. Penghao, Y. Bing. Lateral Cross Localization Algorithm Using Orientation Angle for Improved Target Estimation in Near-Field Environments. *Information*, 2016, 7(3), 40.
- [14] L. Ming, T. Liang. A Cluster-Based Passive Direction Finding Cross Location Method.

- International Conference on Information Science & Control Engineering. IEEE, 2016.
- [15] J. Zhenyu, Y. Ruiming, L. Guanna, et al. Research and application of indoor location technology based on amplitude comparison zoning method. *Electrical Measurement & Instrumentation*, 2018.
- [16] D. Xiong, G. Cui, L. Feng, et al. A location and tracking method for indoor and outdoor target via multi-channel phase comparison. *International Conference on Information Fusion*. IEEE, 2017.
- [17] A. N, Xiao-Jun. Research on DF Based on Improved Phase Interferometer. *Radio Engineering of China*, 2009.
- [18] D. F. Albuquerque, J. M. N. Vieira, S. I. Lopes, et al. Doppler resilient modulation in a CDMA-based acoustic local positioning system. *International Conference on Indoor Positioning & Indoor Navigation*. IEEE, 2016.
- [19] D. J. Sadler. Accuracy of Adcock Watson-Watt DF in the Presence of Channel Errors. *Sensor Signal Processing for Defence Conference*. 2019.
- [20] J. H. Bieging, et al. Interferometer measurements of atmospheric phase noise at 86 GHz. *Radio Science*, 19(6), 2016, pp.1505-1509.
- [21] M. Hu, Y. Jian-Bo, L. Peng. The Actuality and Development of Phase Interferometer Technology. *Electronic Information Warfare Technology*, 2010.
- [22] Z. Wu, S. Bian, B. Ji, et al. Short baseline GPS multi-frequency single-epoch precise positioning: utilizing a new carrier phase combination method. *Gps Solutions*, 2016, 20(3):373-384.
- [23] X. Yang, C. Zhan-zhong. Two-Dimensional Circular Array Real-Time Phase Interferometer Algorithm and its Correction. *International Congress on Image & Signal Processing*. IEEE, 2009.
- [24] Z. Yonghui. Discussion on Increase of Direction Accuracy and Angle Range of Phase Interferometer. *Fire Control Radar Technology*, 2002.
- [25] S. Li, L. Chen, Y. Zhao. QPSK Carrier Tracking Method with a Large Pull-in Range for Satellite Communications. *IEEE International Conference on Signal and Image Processing*. 2018.
- [26] G. A. Leonov, Kuznetsov, et al. Analytical Method for Computation of Phase-Detector Characteristic. *IEEE Transactions on Circuits and Systems*, 2012.
- [27] J. R. Francis, A. Gupta. Phase detector for high speed clock recovery from random binary signals. 2000.
- [28] B. Pervan, F. C. Chan. Detecting Global Positioning Satellite Orbit Errors Using Short-Baseline Carrier-Phase Measurements. *Journal of Guidance Control and Dynamics*, 2012, 26(1):122-131.
- [29] L. Lu, Y. Li, C. Rizos. Virtual baseline method for Beidou attitude determination-An improved long-short baseline ambiguity resolution method. *Advances in Space Research*, 2013, 51(6):1029-1034.
- [30] S. Liu, L. Zhang, J. Li, et al. Dual frequency long-short baseline ambiguity resolution for GNSS attitude determination. *IEEE/ION Position, Location and Navigation Symposium*. IEEE, 2016.
- [31] J. Woillez, P. Wizinowich, R. Akeson, et al. First faint dual-field off-axis observations in optical long baseline interferometry . *The Astrophysical Journal*, 2014, 783(2):104.
- [32] L. Ping, W. Guohong, X. Yan, et al. A single-station location method based on long baseline interferometer. *14th International Symposium on Communications and Information Technologies*, IEEE, 2015.
- [33] L. Zhang, Z. Xu, D. Wu, et al. Influences analysis of polarization on phase-interferometer PRS angle measurement with decoy of coherent source. *Chinese Journal of Radio science*, 2012.
- [34] H. E. Jing, Z. Linghou. An Angle Measurement Algorithm for Multi-Baseline Interferometer Under Near Field Target Geometry. *Measurement & Control Technology*, 2015.

YUANPING SHI carried out the investigation..  
George Smith has implemented the simulation and the optimization.  
PENGCHENG ZHAO was responsible for the Statistics.  
Contact author: Hong-xia Jia  
Contact Email: jiahongxiaxia@163.com