

Studies regarding Finishing and Work Hardening the Internal Surfaces by Radial Vibratory Rolling Method

BADEA LEPADATESCU, ANISOR NEDELICU

Department of Manufacturing Engineering

Transylvania University of Brasov

B-dul Eroilor nr.29, Brasov

ROMANIA

lepadatescu@unitbv.ro, a.nedelcu@unitbv.ro

Abstract: - The paper presents a series of studies regarding the influence of the main constructive and cinematic parameters of the finishing-work hardening tools, on the durability of these tools and on the productivity of the manufacturing process. Thus, is studying the influence of the diameter of the rolling elements (balls) and the angle of the pressure cones " α " on the productivity of the machining, as well as the influence of the ratio between the pulsation of the rolling elements and the rolling speed, on the distribution of the unitary efforts, respectively on the durability of the tools used.

Key-Words: - rolling vibration, work hardening, finishing, accuracy.

1 Introduction

Previous research carried out in order to finishing and work hardening the inner and outer cylindrical surfaces of the metal parts processed by rolling-impact vibrations revealed the possibility and the advantages of using this new method, both with the use of single vibrating ball tools [1] and of the multiple roller tools [2],[3].

Considering the advantages offered by this manufacturing process and the results obtained in finishing and work hardening the inner cylindrical surfaces of the workpieces by radial vibratory rolling method, using the multi-ball rolling tools [4], it will be presented below the study of the construction of such tools used in cold working.

2 Description of the method

The finishing and work hardening of the internal cylindrical surfaces of the workpieces by radial vibratory rolling process can be accomplished with tools, which from the constructive point of view are similar to the tools used for axial rolling-vibration [5]. For these reasons, for the study it was adopted the construction of rolling tools with mobile cage and fixed cones (without rotating motion).

In this construction (Fig. 1), the radial pulse of the rolling elements (balls) 4 is caused by the axial displacement of the conical ring 5 which receives the movement from a mechanically, hydraulically,

pneumatically or electrically operated vibratory mechanism. The workpiece is fixed to the clamping and driving mechanism 1, which generate a rotary motion during the process. Due to the axial feed of the tool "s", the rolling elements will generate on the bore surface of the workpiece 2, a boundary work hardened layer.

As the pressure generated through the balls exceeds the yield point of the piece-part material, the surface is plastically deformed by cold flowing of subsurface material. The result is a mirror-like finish and a tough, work-hardened surface with load-carrying characteristics which make this machined surface superior to finishes obtained by abrasive metal-removal methods.

The contact of balls to the workpiece is ensured by a pressure. At this point, while the uneven sections parts are being pressed, the gaps in bottom are filled up simultaneously.

This process that we called as plastic deformation is repeated as long as the rotation, pressing and progressing continue. Therefore the smooth and bright surfaces are obtained.

The degree of non-homogeneity of the boundary layer depends on a series of the constructive and cinematic factors of the technological system.

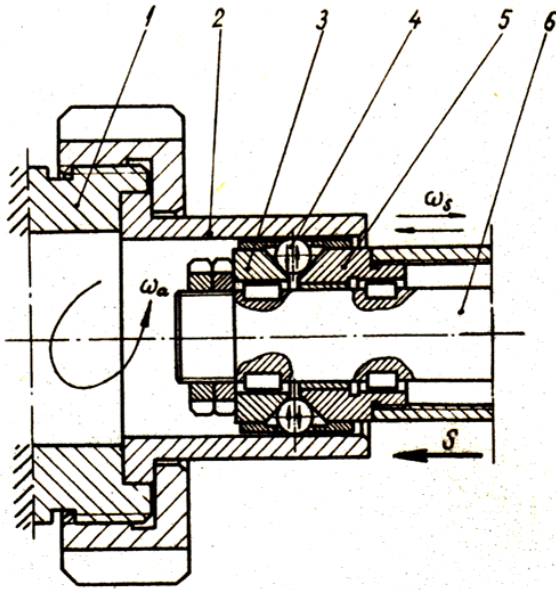

Fig.1 Schematic illustration of the radial vibratory rolling process.

The degree of non-homogeneity of the boundary layer depends on a series of the constructive and cinematic factors of the technological system. The most important of these factors are: the number of running balls k and their diameter, the pulse of the body tool ω_s , the axial feed "s", the force applied to the running balls P , and the angular speed of the machined workpiece ω_p [4].

3 The study of the influence of the diameter of the running balls on the process productivity

An important parameter for the construction of rolling tools is the diameter of the rolling balls. The size of this parameter depends on a number of factors such as the roughness of the workpiece rolled surface, the depth of the work hardened layer, the feed per rotation of the tool etc.

From previous research [2], it is known that for a certain value of roughness, R_T (R_{max}), the feed per rotation of the ball S_b is given by the expression:

$$S_b = 2\sqrt{2 \cdot R_b \cdot R_T - R_T^2} \quad (1)$$

The nominal feed of the body tool s_r at one rotation of the workpiece is given by:

$$s_r = n_c \cdot s_b \quad (2)$$

in which: s_r represents the feed of the body tool in one rotation of the workpiece, n_c - the number of running balls adopted; s_b - the feed per balls.

The maximum number of balls that can be adopted on a multi-balls tool can be determined using the relationship:

$$n_c = \frac{\pi(R_p - R_b)}{R_b} \quad (3)$$

where R_p is the radius of the surface to be machined, and R_b is the radius of the ball.

In this case the relation (2) gets the form:

$$S_r = 2\pi \frac{R_p - R_b}{R_b} \sqrt{2 \cdot R_b \cdot R_T - R_T^2} \quad (4)$$

In order to determine the influence of the working beam radius on the amount of rotation and productivity, the relationship (4) will be studied as a function of a single variable $S_r = \varphi(R_b)$.

By removing the values of the variable for which the function becomes negative (in order not to lose its physical meaning), the existing domain of the function is the interval $[\frac{R_T}{2}, R_p]$.

If the function $S_r = \varphi(R_b)$ is derived, and equals zero, the roots that express the abscissa of the extreme points are obtained:

$$R_b(1,2) = \frac{-R_p \pm \sqrt{R_p^2 + 4R_p R_T}}{2} \quad (5)$$

From the two solutions $R_b(1)$ and $R_b(2)$, only the solution $R_b(1)$ is in the definition domain:

$$R_b(1) = \frac{-R_p + R_p^2 + 4R_p R_T}{2} \quad (6)$$

The graphical presentation of the function $s_r = \varphi(R_b)$ is given in Fig.2.

From this figure and relation (6) it results that a maximum is reached for values of R_b much lower

than the admissible limit value $R_b = (0, 05 \dots 0, 30) R_p$.

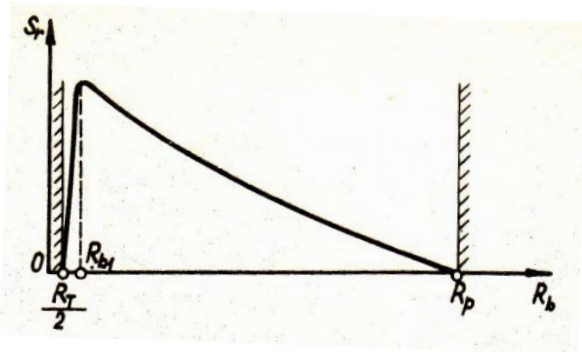

Fig.2 The graphical presentation of the function $s_r = \varphi(R_b)$.

From the above results, the general conclusion is that for the same value of the roughness of the rolled surface " R_T " the feed per rotation of the tool " s_r " and the productivity of the process by the described method increase if the diameter of the working balls decreases.

4 Study on the distribution of unitary stresses on the circumference of the pressure cones

Due to the pressing force between the balls and the pressure cones, the contact area (at static loading) takes the form of a calotte whose projections on a

plane tangent to the initial point of contact can be approximated by an ellipse [4, 6].

In this case the tensions that originate in the contact area are distributed over the entire deformation surface after the OZ coordinate of the semi-ellipsoid of the normal stresses built on this surface.

The bigger axis of the contact ellipse is in the axial direction of the assembly, that is, in the plane where the degree of hugging is maximum, and the minor axis in the direction of the rolling process.

In the real processing case, considering the pulsating working regime and the rolling motion of the cone rolling bodies, the appearance of the elongated, successive disposed and connected semi-ellipsoid forms.

Due to the fact that there are several rolling bodies in the work area, the unitary forces caused by each rolling body will be disposed offset on the circumference of the pressure cones.

In order to determine the degree of unevenness of the unitary effort distribution, as a measure of the durability of the pressure cones, we will study the distribution of the maximum unitary stresses of two adjacent rolling bodies.

If the edge of the imaginary epure of the maximum unitary effort, carried out in a normal plane at the pressure cone, in the rolling path area, can be assimilated to a sinus curve (Fig.3).

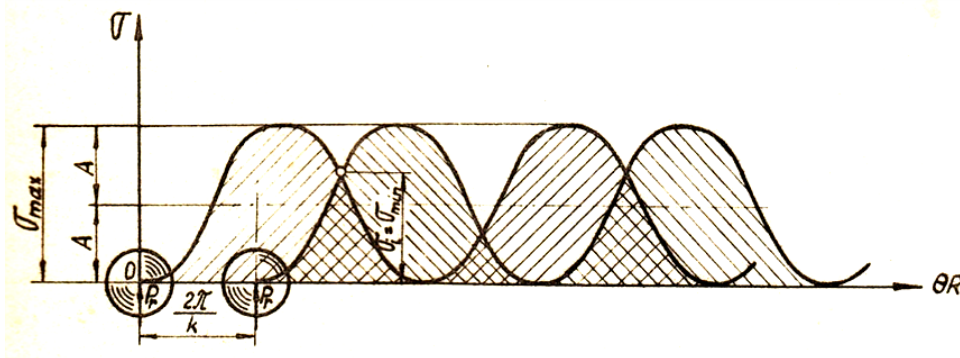

Fig.3 Edge of the imaginary epure of maximum unitary effort.

The equation of the epure contour line of the maximum unitary effort of the first balls, which has as its starting point the origin of the coordinate system $(\sigma, \theta R)$ is given by the relation:

$$\sigma_1 = A(1 - \cos\theta) \quad (7)$$

and for the second ball:

$$\sigma_2 = A \left[1 + \cos \left(\theta - 2\pi \frac{\omega_s}{k \cdot \omega_r} \right) \right] \quad (8)$$

in which: A- represents the amplitude of the sinusoid; θ - pulsation of balls; ω - the angular rotation speed of the rolling balls on the circumference of the pressure cones; k - the number of rolling balls.

As a measure of the degree of unevenness of the unitary stress distribution, the difference between the maximum unitary effort σ_{max} and the minimum unitary effort σ_{min} , which are located at the first intersection of the contour lines of the epures drawn on the two balls (Fig.3). In order to determine the intersection point of the two epures σ_{max} , respectively σ_{min} , equals the relations (7) and (8), after which results:

$$\sin \left(\pi \frac{\omega_s}{k \cdot \omega_r} \right) \sin \left(\theta - \frac{\pi \cdot \omega_s}{k \cdot \omega_r} \right) = 0 \quad (9)$$

Equation (9) admits solutions:

$$1) \frac{\omega_s}{k \cdot \omega_r} = n, \text{ for any } n = 0, \pm 1, \pm 2, \dots \quad (10)$$

or:

$$2) \theta = \frac{\pi \cdot \omega_s}{k \cdot \omega_r} \quad (11)$$

When using the first solution, there is a total overlap of the epures and the edges of these epures respectively, in which case the degree of non-uniformity becomes maximum.

If the second solution is adopted and replaced in relation (7), the coordinate of the point of intersection of the edges of the two epures is obtained, respectively:

$$\sigma_i = A \left(1 - \cos \frac{\pi \cdot \omega_s}{k \cdot \omega_r} \right) \quad (12)$$

If it is accepted that:

$$\sigma_{max} - \sigma_{min} = \lambda \cdot \sigma_{max} \quad (13)$$

in which: λ has the meaning of the non-uniformity factor; $\sigma_{max} = 2A$; $\sigma_{min} = \sigma_i$, can be determined after the necessary replacements the ration of synchronization "is" between the pulsation of the rolling elements and the angular velocity ω_r of the rolling elements around the center axis, depending on the number of rolling balls adopted "k", and the degree of non-uniformity λ admitted for the

distribution of unitary efforts on the circumference of the pressure cones, as follows:

$$i_s = \frac{\omega_s}{\omega_r} = \frac{k}{\pi} \arccos(2\lambda - 1) \quad (14)$$

This relationship (14) allows to accurately determining the synchronization ratio "is", which ensures a rational exploitation of the tools used.

5 The kinematics study

In the case of the use of ball rolling tools as is shown in Fig. 1, the angular speed of rotation of the contact points between the rotating bodies (moving) and the working surface of the blank (fixed) as a expression of the rolling speed, is equal to the angular speed of rotation of the rolling elements around the central axis. In order to determine these speeds it is necessary to study the kinematics of the whole ensemble.

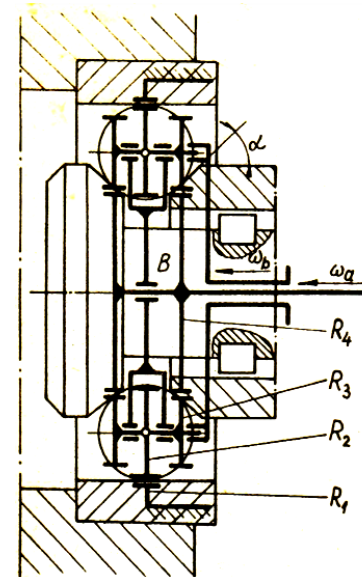

Fig.4 Scheme of a planetary mechanism used for the rolling operation.

Analyzing the bodies system made up of the blank piece, the rolling bodies together with the supporting cage and the pressure cones, it is observed that they behave cinematically as a planetary mechanism similar to that shown in Fig.4.

With this mechanism, the rotation of the center shaft (rigid with the main shaft of the machine tool) is transmitted to the satellites (working balls) by means

of the two inner wheels R_4 (the rolling radius of the pressure cones). In this case, the leading element is considered to be the main shaft of the rolling head, and as a driven element the satellite arm B.

Using the same previously used calculation method (8), it is easy to find the angular rotation velocity of the satellite arm ω_b , depending on the angular rotation velocity of the main shaft of the rolling head ω_a .

Thus we have:

$$\omega_b = \omega_a \frac{R_2 \cdot R_4}{R_1 \cdot R_3 + R_2 \cdot R_4} \quad (15)$$

in which; R_1 - is the radius of the rolling diameter of the wheel 1; R_2 - is the radius of the rolling diameter of the wheel 2; R_3 - is the radius of rolling radius 3; R_4 - is the radius of wheel diameter 4.

From Fig.1 and Fig.4 it can be shown that:

$$R_3 = R_b \cdot \cos \alpha \quad (16)$$

$$R_4 = R_p - R_b(1 + \cos \alpha) \quad (17)$$

in which: R_b - is the radius of the rolling ball; R_p - is the radius of the machined surface of the workpiece; α - is the pressure angle.

Since the angular rotation speed of the contact points between the rolling balls and the work surface, considered as the angular velocity ω_r , is equal to the angular rotation velocity of the satellite port arm ω_b , and after the required relationship (15) becomes:

$$\omega_r = \omega_b = \omega_a \frac{R_p - R_b(1 + \cos \alpha)}{(R_p - R_b)(1 + \cos \alpha)} \quad (18)$$

From the analysis of the relationship (18) it results that when using the mobile cage rolling tools (Fig. 1) the actual rolling speed depends on the value of the pressure angle " α ", the diameter of the rolling balls D_b and the diameter of the workpiece surface D_p , namely: the actual rolling speed increases if the pressure angle " α " increases and the diameter of the working balls decreases.

6 Conclusions

Using the method of finishing and work hardening the internal surfaces of the workpieces by radial vibratory rolling method, it is obtained some advantages and benefits as follows:

- Improved surface finish as fine as 0.1 to 0.2 R_a ;
- Improved size control –tolerances within 0.01 mm or better;
- Increased surface hardness – up to 5 to 10% or more;

Other benefits include:

- Reduced friction;
- Reduced noise level of assembly;
- Enhanced corrosion resistance;
- Elimination of tool marks and minor surface imperfections;
- Replaces expensive secondary operations, such as grinding, honing, or lapping;
- Faster production at lower cost, as compared to other finishing processes.

References:

- [1] Blazinski, T. Z., *Plasticity and Modern Metal forming Technology*. New York: Elsevier, 1989.
- [2] Maier, A. – *Work hardening of the superficial layer and finishing the parts through the rolling method*. Experience of company "1 Mai" Ploiesti, ICDT, Bucharest, 1968.
- [3] Hosford, W. F., and R. M. Caddell. *Metal Forming: mechanics and Metallurgy*, 2nd ed. Englewood Cliffs, New Jersey: Prentice_Hall, 1993.
- [4] Lange, K., *Handbook of Metal Forming*. New York: McGraw-Hill, 1985.
- [5] Underwood, L. R., *The Rolling of Metals*, Vol.1. new York: Wiley, 1990.
- [6] Wusatowski, Z., *Fundamentals of Rolling*. New York: Pergamon, 1989.
- [7] Starling, C.W., *The Theory and Practice of Flat Rolling*. London: The University of London Press, 1992.