

Evaluation of an aeration system, Bojórquez Lagoon, Cancun, Mexico

ROBLES ISIDRO, GONZALEZ JOSE ALFREDO

Department of Environmental Hydraulics

Instituto Mexicano de Tecnologia del Agua

P. Cuauhnahuac No. 8532, Col Progreso, Jiutepec, Morelos, CP 62550

MEXICO

jrobles@tlaloc.imta.mx <http://www.imta.gob.mx>

Abstract: - This paper describes the evaluation of an aeration system located in the Bojórquez lagoon, Cancun, Mexico, a suction point and another at a distance of 300m discharge with a structure in the form of waterfalls by steps is presented. Three critical sites odours due to clandestine wastewater discharges were identified. Because Bojórquez is a touristic and protected area, it was not possible dredging as a method of remediation. When comparing the DO of the calculated against measured in the field, good agreement was obtained, with a saturation level of 6.3 mg/l in water to prevent the release of gases such as methane and hydrogen sulphide and nutrients such as phosphorus and nitrogen from the sediment to the water column.

Key-Words: - Aeration, restoration technics, hydraulic structures, eutrophication, wastewater discharges, coastal lagoons

1 Introduction

Today as in the past has recognized the importance of hydraulic structures in improving water bodies that are deficient in oxygen levels. Until recently there were no methods to evaluate, appropriately, the increase of oxygen in the water column with the application of special devices or structures.

Measurements were only oxygen in the water pouring laboratory prototype. With contributions from [1], [2] prediction equations oxygen transfer only some important factors such as the drop height in the case of weirs were considered.

With studies and subsequent measurements in laboratory models and prototypes, to the prediction equations important factors were included in the aeration process in water bodies.

In the Mexican Institute of Water Technology (IMTA, Morelos, Mexico) initiated a study related to the process of eutrophication of the Nichupte Lagoon in Cancun, Mexico. In later years, the focus was on the lagoon Bojórquez, body of water that is specifically part of the Nichupte lagoon system in areas with low levels of dissolved oxygen, which correspond to areas wastewater discharges hotels. In this situation, it is added that these regions are stagnant pond. Under these conditions, especially in the hot summer nights with little wind, the lake produces odours, creating obvious drawbacks to the tourist area.

In early studies aeration equations taking into account factors such as the shape of the spillway, in the case of falling water free surface, drop height, presence of concentrations of dissolved inorganic salts, etc. Subsequent studies [2] integrate the equations as an expense factors, drop height, depth water inlet (factors influencing water oxygenation in case spouts). The

equations resulting from these studies were generated from measurements in both field and laboratory.

2 Critical zone of eutrophication

The study area is located in the state of Quintana Roo, Mexico, within the Nichupte lagoon system in the Bojórquez lagoon where tourist area is located with the coordinates N 21°09'38" and O 86°50'51", Fig. 1. For years, the resort gets a lot of tourists that flock to this famous place in the Mexican Caribbean.

Due to inadequate control policy discharges of wastewater are discharged directly to the Bojórquez Lagoon has a significant amount of organic load in the water column.

On the other hand, the rapid expansion of residential complexes has gained ground where once there were mangroves. These plants have an important role in mitigating the polluting effects in the presence of nutrients inside the lagoon historically in the study site function. Since mangroves play a purifying function, the function as natural filters reducing the adverse effects of eutrophication.

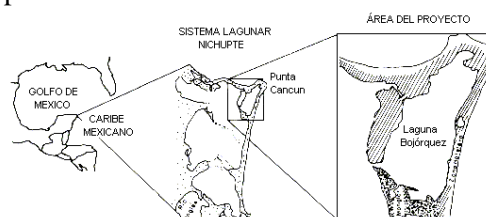

Fig. 1. Location of the study area.

One of the reasons why the problem is accentuated because it exists in the marsh complex there is poor circulation between the lagoon and the open sea.

This results in critical points of contamination in the warm windless nights in Bojórquez, where are released into the water column, gases such as hydrogen sulphide, methane, as well as nutrients such as phosphorus, nitrogen and others. The main discomfort are the odours that are seen in the peripheral zone to clandestine discharges.

Because certain areas of the lagoon Bojórquez have low circulation, they have bad odours surrounding hotels with consequent inconvenience for tourists. These zones are identified and shown in Fig. 2.

To try to address this problem, a mapping of the lagoon was performed to determine where you could build aeration systems trying to avoid protected areas by government agencies, recreational water traffic, etc. The determination of these regions is shown in Fig. 2 and are basically three points where a bad odour is generated for the reasons explained above.

In addition, a monitoring program of the main indicators of eutrophication in the lake as chlorophyll a, pH, dissolved oxygen, temperature, BOD, COD, etc. are implemented. The results of these analyses showed that most exceeded the maximum allowable current standard.

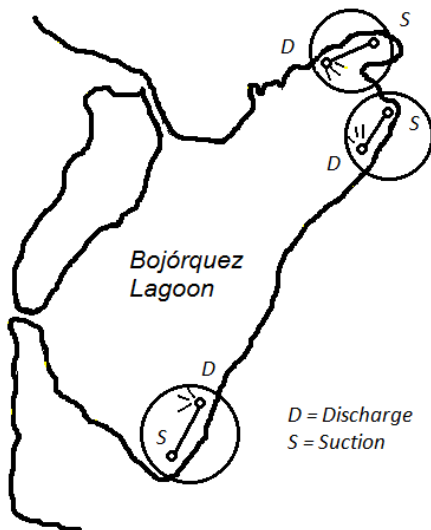

Fig. 2. Eutrophication in critical areas Bojórquez Lagoon.

To reduce the organic load in the program cancellation clandestine discharges from hotels by the government agency *Fonatur* began. In addition, the government agency *Semanat* proposed a system consisting of aeration pyramidal structures and steps so that, based on waterfalls, water increase the amount of dissolved oxygen.

Basically, there were two distant points approximately 300 m apart, at one end a pump drew water from low dissolved oxygen and sent to the second discharge point where the structure was based cascades Fig. 3 is had.



Fig. 3. Structure built in the lagoon aeration Bojórquez, Cancun, Mexico.

3 Gas transfer process

From the first law of Fick diffusion, diffusion percentage $2M/2t$ of a gas through a water-gas interface area A within a liquid body at rest, is a function of the diffusion coefficient Dm molecular gas and gas concentration gradient $2C/2x$:

$$\frac{\partial M}{\partial t} = Dm A \frac{\partial C}{\partial x} \tag{1}$$

The distribution process gas through the liquid body by diffusion is only extremely slow, but this can be accelerated by mixing as this physically distributes the solute and leverages the capabilities of diffusion and maintains the concentration gradient up through the interface.

One of several theories which is commonly accepted as wider contemplates the gas transfer equation given as:

$$\frac{C_s - C_t}{C_s - C_o} = \frac{1}{r} = e^{-K_L(A/V)t} \tag{2}$$

in which r is referred to as the relationship deficit; K_L is a function of gas diffusion; A is the area of air/water interface; V is the volume of the liquid body; C_o , C_p , C_s , are the initial concentration of dissolved oxygen, at time t and saturation respectively.

4 Oxygen transfer type spillway structures

The work published a few years ago regarding the transfer of oxygen in pourers not brought to light any useful conclusions for evaluation purposes. Some authors [3] even published nomograms for calculating the aeration capacity in free fall, which includes the effects of temperature, shock, pollutant load and number of steps (waterfalls).

The incongruities of measurement results in prototype and models, environmental department [4] and [5], were attributed to different qualities of water and the effect of mixing water inlet downstream of the weir. Expression ratio deficit in terms of h , alone, is not satisfactory since the effects of shock and spray pattern [6] are important also.

Subsequently, the work done by [2] included the effects of the discharge, water fall and water inlet jet in the prediction formula. Because this expression was based on laboratory tests conducted there are some doubts about its general application. However, the results of the comparison of measurements on prototypes against calculations with respect to the formula above equations had a better result.

Nakasone equation is composed of a set of four sub equations which in its general form is expressed as:

$$\ln r = C_a (D + 1.5Hc)^\alpha q^{\beta-1} H^\gamma \quad (3)$$

in which C_a , α , β and γ are constants.

The value of the constant C_a and exponential numbers were determined from many measurements and laboratory experiments with the condition that the bottom of the canal downstream out horizontally.

5 Factors affecting the transfer of oxygen

The increased percentage of oxygen in the water through the air/water interface by a special structure, is a very complex phenomenon and difficult to quantify. So far the comparison of measurements with calculation of expressions has identified some of the main factors involved in oxygen transfer.

Drop height: Through observations Nakasone, the exponential number of drop height h ($D + 1.5 Hc$) of equation 3, changes in $h = 1.2$ m, Fig. 4, although other authors, Albrecht (2) and Kroon (10) indicate the transition point as $h = 0.8 - 1.0$ m.

Discharge: There are two criteria, one that says that an increase in the discharge corresponds a

decrease in aeration efficiency. For example, the graphs of [7], [8]. The second criterion dictates that for an increase in the discharge there is an increase in aeration efficiency up to a certain point where for increased expenditure have decreased aeration efficiency. This is the case of the equation 3 Nakasone for which the highlight is $q = 245 \text{ m}^3/\text{h}\times\text{m} = 65 \text{ l/s}\times\text{m}$.

Tail water: For each combination of discharge and fall height there is a maximum depth for the bubbles no longer penetrates. Thus, a limit is restricted in aeration efficiency, since this factor is important. For the case where bubbles do not reach the bottom, the researcher [3], he found that the aeration efficiency is stable for greater depths than $2/3 h$. Therefore, for depths $H \geq 0.667 h$ is necessary to adopt the value of $0.667 h$ to H in Equation 3.

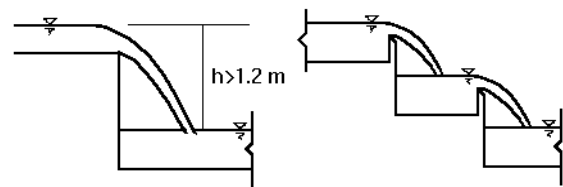

Fig. 4 is preferred to use a larger number of steps when the drop height is greater jet 1.2 m.

6 Aeration systems

The ventilation system will provide an increase in the percentage of dissolved oxygen levels of water which is treated, in order to avoid possible undesirable levels of oxygen. Especially for critical seasons and times that have this tendency.

By applying the equations described the structure design aeration as waterfalls was performed with the results shown in Fig. 5, which show that for the case to reach the value of 6.3 DO (dissolved oxygen) is required lower structure height when more steps are for the case of one.

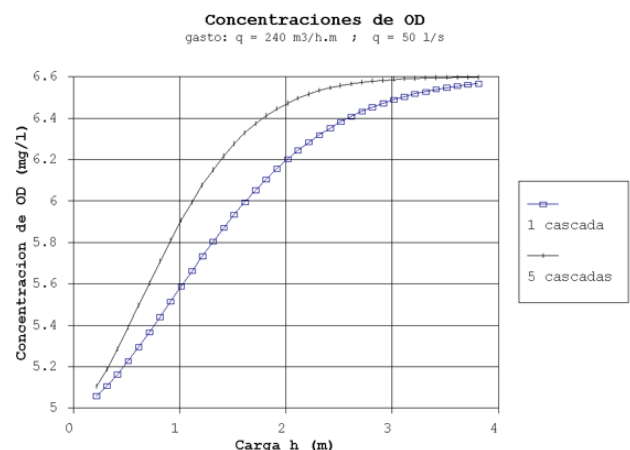

Fig.5. Calculation used to decide the number of steps to be used in the structure of aeration.

7 Structure and dimensions geometry type waterfall

Considering that the breather structure is part of a larger system, composed of headworks, driving system based pipeline, the same aeration system and discharge structure. The aeration device or structure it will constitute the following parts:

- Tank receiver
- Steps drop (waterfalls)
- Discharge structure

The flow pumped to the structure was 50 l/s, with saline water nature.

As shown in Fig. 6, each of the steps has the following dimensions (in m): $1.5 \times hc$ (tight critical = 0.0768) = 0.115 ; D (drop height) = 0.38 ; h (free fall) = 0.50 ; $H(D)$ = 0.33 ; l_0 (mixing length) = 1.76 . These dimensions are the same for each of the steps (waterfalls).

The weirs have a length of 0.75 m, will be thin at the ridge thickness not exceeding 2 mm top edge bevel. Pouring should be flush with the horizontal to ensure a uniform drop the jet.

The weirs are serrated with notches 7 each, as shown in Fig. 7, with a width of each groove of 0.06 m in width between 0.04 m and 0.045 m at the ends.

The notch height must ensure the separation of the sheet generated in individual jets (7 jets), estimated at 0.164 m, it is necessary that the individual jets do not join on top of weir notched.

The structure should allow efficient ventilation in the lower surface of each nappe.

The structure was formed with a total of 5 steps (waterfalls), which amounted to a total height of 2.5 m, obtained from the difference between water levels up and down the structure formed by the steps.

The length of the steps (cascades) was the sum of the lengths for each individual step mixed with approximately 8.8 m.

The total length of steps will add: 1 m in length, as a receiving channel at the spillway of the first step, 0.70 m as the length of the structure that receives water from the pipeline (see Fig. 8).

The depth of the receiving tank of water from conduction will be approximately 1.2 m. The receiver tank includes a structure to allow a quiet flow to the first step (cascade).

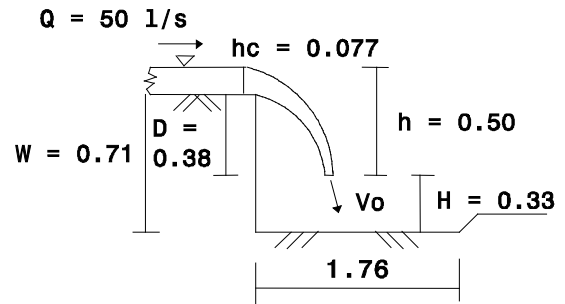

Fig.6. Dimensions of each step (cascade).

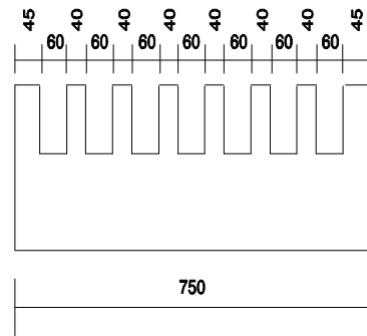

Fig.7. Weir notched dimensions in mm.

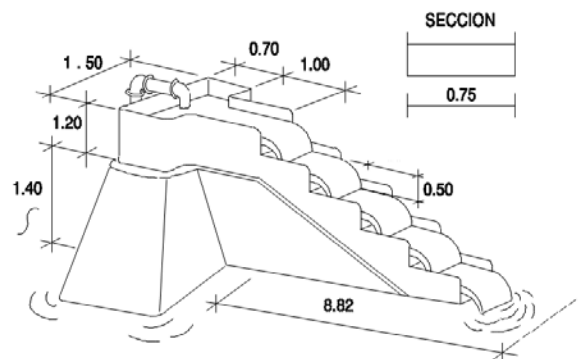

Fig.8. Overview of the structure aeration.

8 Results of the implementation of aeration system

Intending to evaluate the performance of the structure in the form of waterfalls, a monitoring program of dissolved oxygen, as the main parameter of interest for this study was implemented.

Monitoring results in one of the structures shown in Fig. 9. As shown, measured data against calculated in the design of the structure fit well. The saturation value of the pond water was 6.3 DO, historical value obtained from sampling at the site.

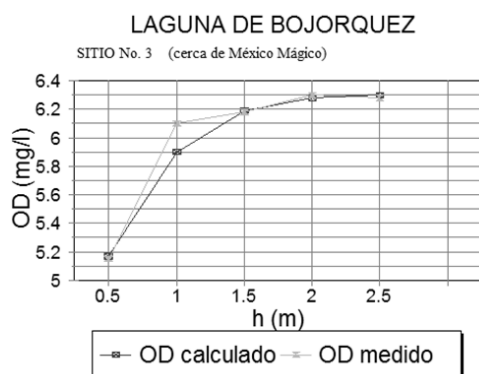

Fig.9. Results of the comparison of the calculated measured against dissolved oxygen.

The monitoring program was extended for at least two months, in which similar results to those shown in Fig. 9.

Because there are a lot of illegal discharges of wastewater to the lagoon from local hotels, tracers were applied to identify illegal discharges and proceeded to penalize the hotel and the closure of such discharges.

8 Conclusions

The main results of the application of an aeration system in critical areas are presented and located in the vicinity of hotels, with bad smells in the lagoon Bojórquez lagoon system located in Cancun in the state of Quintana Roo, Mexico.

Three sites with odour problems caused by the release of gases such as methane, hydrogen sulphide and nutrients such as nitrogen, phosphorus, among other from sediment to the water column were located. In the system application program sanctions hotels with clandestine dumping lagoon included.

One of the biggest problems was the slow circulation area that has Bojórquez lagoon with the rest of the lagoon system. With this, it was possible to reach the saturation level of water at critical points Bojórquez lagoon that was 6.3 mg/l. Since, on warm evenings, windless and in photosynthesis ceases, the DO content in the water column is drastically reduced.

At the time of operation of the three structures aeration lagoon Bojórquez was able to reduce discomfort due to odours. So far only reducing odours qualitatively determined, but continued with the campaign monitoring quality parameters of water, of which a significant reduction in these parameters such as chlorophyll a, BOD, COD was observed and an increase in the DO concentration.

References:

- [1] Apted, P. y Novak, P. *Some Studies of Oxygen Uptake at Weirs*, Proceedings of the XV Congreso, IAHR paper, 1973.
- [2] Nakasone, H., *Comparison of Falls and Spillways at River with Results of Experimental Channels*, Transactions, JSIDRE, Vol. 83, 1979.
- [3] Albrecht, D., *Schatzung der Sauerstoffzufuhr durch Wehre und Kaskaden*, Die Wasserwirtschaft, Vol. XI, 1969.
- [4] *Notes on Water Pollution*, Department of the Environment, 1973.
- [5] Holler, A. G., *The Mechanism Describing Oxygen Transfer from the atmosphere to Discharge through Hydraulic Structures*, Proceedings, XIV Congress, International Association for Hydraulics Research, Paper A45, 1971, pp. 373-382
- [6] Londong, D., *Flusswasserbeluftung an der Lippe*, presented at the May 17-18, Haus der Technik, Meeting No. 104, Essen, Germany, 1967.
- [7] Van der Kroon, G. T. M., and Schram, A. H., *Weir Aeration-Part I*, H2O, No. 22, 1969, pp. 528-537.
- [8] Van der Kroon, G. T. M., and Schram, A. H., *Weir Aeration-Part II*, H2O, No. 22, 1969, pp. 538-545.