

A Signal Identification Model for MIMO Design

¹A.VIMALA, ²DR.P.KARTHIGAİKUMAR, ³Y.CAMY JOSHYA,

Department of ETE
Karpagam College of Engineering
INDIA

¹tel2vimala@gmail.com, ²p.karthigaikumar@gmail.com, ³shiyasmith@gmail.com

Abstract:- This paper presents the design of MIMO signal detector based on LTE-A downlink. The detector use multiple input multiple output (MIMO) modes like Spatial multiplexing (SM), Spatial Diversity (SD) and Space Division Multiple Access (SDMA). Area efficiency is achieved by Near Maximum detection algorithms. The goal of the project is to develop a parallel multistage VLSI architecture to achieve area efficiency and high detection throughput. The MIMO modes are implemented in the pre processing stage of MIMO detector architecture. The parallel multistage VLSI architecture is used to achieve high detection throughput where multiple nodes are processed simultaneously in each layer. The Euclidean distance Calculation and interference cancellation scheme reduces the critical path delay of the system. The detector design uses 2×2 antenna, 64 QAM modulations with three MIMO modes.

Key-Words:- Multiple Input Multiple Output Signal detector (MIMO), spatial diversity (SD), space division multiple access (SDMA), Spatial Multiplexing(SM), Very Large Scale Integration (VLSI)

1 Introduction

The requirement of International Mobile Telecommunications Advanced (IMTA-A) standard for fourth generation wireless networking is achieved using third generation partnership project (3GPP) with LTE-A downlink. The Multiple Input Multiple Output (MIMO) communication system plays a key role in fourth generation mobile wireless communication standards to increase the data rate to several mega bits per second. The signal detector is designed based on some tree search algorithm, which achieves near ML performance with less complexity than optimal ML method performance. The MIMO transmission system uses multiple antennas at both the transmitter and receiver sides [1-3]. The basic antenna configuration used in 3GPP-LTE is 2×2 antennas which can be further increased to 4×2 or 4×4. In general to achieve beyond gigabit per second data rate LTE-A downlink is combined with Orthogonal frequency division multiple access scheme.

The VLSI implementation of MIMO detector is used to achieve high detection throughput and area efficiency [4-5]. The main objective of this project is to design an area efficient MIMO detector that supports spatial

multiplexing(SM), Spatial diversity(SD) and space division multiple access(SDMA) signal detection that provide Near maximum detection performance. At the algorithm level the detector is designed based on the tree expansion according to reliable nodes and extend only the reliable nodes so that only fewer branches are extended for complexity reduction[6-7]. For theoretical analysis we use algorithm level approaches and the real prediction of detector is analyzed from the parallel multistage VLSI architecture.

The development process starts from spatial multiplexing signal detection, implemented using an imbalanced expansion scheme applied to Fixed Complexity sphere decoder (FSD) [8]. The FSD algorithm is used to reduce complexity reduction. The next step is to develop the detection scheme for spatial diversity and space division multiple access scheme [7]. For theoretical verification we use real value successive interference cancellation algorithm for spatial diversity signal detection. In the detector architecture real value decomposition or qr decomposition at the pre processing stage and interference cancelation unit at the detection stage supports spatial diversity signal detection mode. For SDMA

mode the Matrix permutation at the pre-processing stage reutilizes the imbalanced FSD algorithm in SM mode. The purpose of matrix permutation is to move the desired signal of each user to the top layer of search tree so that the unwanted detections are avoided [9-12]. The performance of MIMO detector is simulated using Modelsim.

The remainder of this paper is organized as follows. In section II we give the description of LTE-A downlink system model. In section III MIMO detection algorithms is proposed. In section IV VLSI architecture is implemented. Section V explains about the results simulated and finally section VI concludes the paper.

2 MIMO System

The LTE-A downlink MIMO transmission system uses one base station (BS) and K-user equipments (UEs) shown in fig.1. Here both the base station and user equipments has N antennas. The received $N \times 1$ complex signal vector in the n^{th} subcarrier of user k is given by

$$r_{k,n} = H_{k,n}^c \sum_{k=1}^K \tilde{w}_{k,n} \tilde{x}_{k,n} + \tilde{w}_{k,n}; n=1,2,\dots,N_{\text{sub}} \quad (1)$$

Where N_{sub} = number of sub carriers,

$\tilde{H}_{k,n}^c = N \times N$ is complex channel matrix between the base station and k^{th} UE,

$\tilde{x}_{k,n} = \tilde{x}_{k,n}^{(0)}, \dots, \tilde{x}_{k,n}^{(P-1)}$ is the P layers of transmitted symbols,

$\tilde{w}_{k,n}$ is the vector of identically distributed zero mean Gaussian noise samples,

$\tilde{W}_{k,n}$ is $N \times P$ precoding matrix selected from finite codebook

In this project $k=1$ and $P=N$ in both SM and SD transmissions. \tilde{W}_k is set to be N dimensional identity matrix in SM system and an Alamouti space frequency coding matrix in SD system [13-14]. For SDMA system, according to 3GPP LTE standard P is set to one, K is set to N and $\tilde{W}_{k,n}$ is chosen such that $\tilde{W}_{k,n}^H \cdot \tilde{W}_{k,n} = 1$ and $\tilde{W}_{l,n}^H \cdot \tilde{W}_{k,n} = 0$ $\tilde{W}_{k,n}^H$ means hermitian transpose of $\tilde{W}_{k,n}$

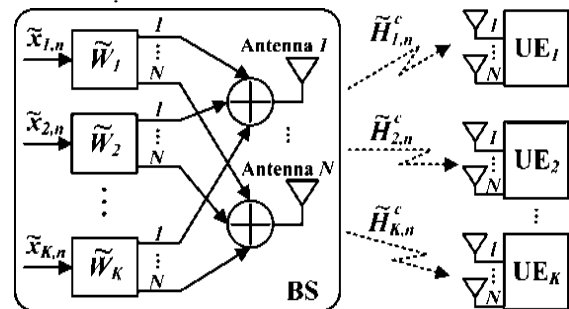

Fig 1: LTE-A downlink transmission system

3 MIMO Detection Algorithms

The objective of MIMO detection algorithm is to recover the original transmitted by knowing the received signal and channel. The MIMO detection with near ML algorithm have better performance and high hardware utilization by sharing most of the operations among different nodes.

3.1 Signal Detection Algorithms for SM Mode

Fixed Complexity sphere Decoder (FSD) algorithm is used for signal detection in spatial Multiplexing (SM) mode. The purpose of FSD algorithm is, it searches only the fixed number of possible transmitted signals, generated by a small subset of all possible signals located around the received signal vector. The FSD transforms the closest point search problem to a tree search procedure by performing QR decomposition to the channel matrix $H=QR$, where Q is unitary and R is upper triangular matrix.

FSD carries the tree search procedure to calculate the partial Euclidean distance (PED) between the nodes of the tree and it is given by

$$T_i = T_{i+2} + inc_i + inc_{i+1}$$

$$inc_i = |y_i - \sum_{j=i+2}^{2N} R_{j,i} x_j - R_{i,i} x_i|^2$$

$$= |\tilde{y}_i - R_{i,i} x_i|^2$$

$$inc_{i+1} = |y_{i+1} - \sum_{j=i+1}^{2N} R_{i+1,j} x_j - R_{i+1,i+1}x_{i+1}|^2$$

$$= |\tilde{y}_{i+1} - R_{i+1,i+1}x_{i+1}|^2 \tag{2}$$

Where T_i is the partial Euclidean distance between the nodes

The reliability of the candidate node is related to the PED, large PED the node is discarded and it is not transmitted and smaller PED the node is transmitted. The imbalanced FSD possess low complexity and hardware saving is good.

3.2 Signal Detection for SD Mode

The real value or QR decomposition at the pre processing stage and interference cancellation at detection stage is used for signal detection in SD mode. The resulting orthogonal real-valued representation of the QR-decomposed ($H_n = Q_n R_n$) system model is then given as (the user index k is also neglected here in the SD mode)

$$y_n = R_n s_n + v_n, n \in [1,2] \tag{3}$$

The inter-antenna interference introduced by \tilde{x}_2 is canceled from $y_n^i (n, i \in [1,2])$ after we got the result of \tilde{x}_2

$$\tilde{y}_n = y_n^i - \sum_{l=3}^4 R_{n,(i,l)} \tilde{S}_n \tag{4}$$

Since $R_{n,(1,2)} = 0 (n \in [1,2])$, the symbol \tilde{x}_1 is detected with a similar method given by

$$I(\tilde{x}_1) = \arg \min_{I(\tilde{x}_1) \in \sqrt{M}} |(y_1^2 - y_2^2) - (R_{1,22} + R_{2,22})I(\tilde{x}_1)|^2$$

$$R(\tilde{x}_1) = \arg \min_{R(\tilde{x}_1) \in \sqrt{M}} |(y_1^1 + y_2^1) - (R_{1,11} + R_{2,11})R(\tilde{x}_1)|^2 \tag{5}$$

The detection results in the proposed algorithm are attained by decoding the real and imaginary parts of \tilde{x}_1 and \tilde{x}_2 separately. Apparently, this approach makes finding the ML nodes much simpler than the complex-value ML algorithm, because the search zone has been reduced from M complex points to \sqrt{M} real

points. It is worth to reemphasize that this simplification is accrued from the real-value/QR decomposition and the interference cancellation.

3.3 Signal Detection for SDMA Mode

Detecting the downlink SDMA signal is unique in that only the signals dedicated to the k th user (i.e., x_k) are reserved. Obviously, the ML detection has the problem of spending too much detecting effort on the unwanted signals ($x_{l,l \neq k}$). To avoid such prohibitive computational waste while maintaining a near-ML performance, we propose to reuse the developed imbalanced-FSD algorithm. Because the original imbalanced-FSD conducts an ambitious search at the top layer of the complex-valued search tree, while using a very simple single-node expansion in the remaining layers, we make a slight modification such that the desired signal x_k is moved to the top layer to guaranteed a near-ML detection. The signal movement is accomplished by introducing a permutation matrix P_k as

$$\tilde{r}_k = H_k^c [\tilde{W}_1, \dots, \tilde{W}_K] P_k \tilde{x}_k + \tilde{w}_k$$

$$= \tilde{H}_k \tilde{x}_k + \tilde{w}_k \tag{6}$$

where $x_k^P = [x_1, \dots, x_{k-1}, \dots, x_k, x_k]^T$ is the transmit vector with x_k being moved to the top layer and $P_k = [p_1, \dots, p_{k-1}, p_{k+1}, \dots, p_K, p_k]$ is the permutation matrix, where p_i denotes an $N \times 1$ vector whose i th element is one, but all others are zeros. Taking H_k as the equivalent channel matrix input, the matrix-permuted-FSD then conducts exactly the imbalanced-FSD tree search to get the estimation result x_k^P , in which x_k is the desired signal for user k , retained and outputted for further processing, while $x_{l,l \neq k}$ are the signals intended for other users, discarded after detection. Since these unneeded signals are detected at the bottom layers of the search tree where relatively low-complexity single-node expansion is performed, the proposed algorithm diminishes the wasted computation efficiently.

4 VLSI Architecture

The VLSI architecture for MIMO detector supports the detection of spatial multiplexing, spatial diversity and space division multiple

access MIMO signals with $2 \times 2/4 \times 4$ antenna and 64 QAM modulation. The goal of this project is to design an area efficient, and high throughput MIMO detector based on these techniques in both architecture and circuit level design. The detector is partitioned into a pre-processing block and four stages of process elements (PEs), corresponding to the eight layers of the search tree in the case of 4×4 MIMO configuration.

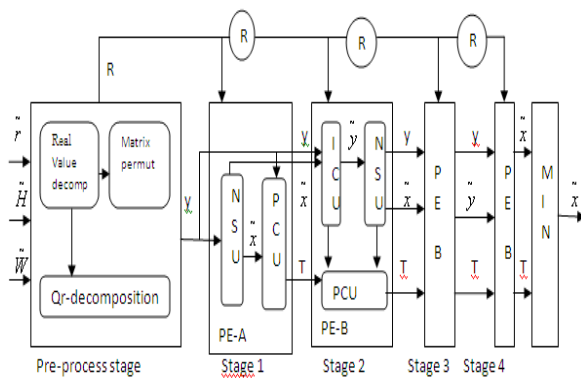

Fig.2 VLSI architecture of MIMO signal detector

Taking the channel matrix \tilde{H}^c , the precoding matrix \tilde{w}_k and the received signal vector \tilde{r}_k as inputs, the pre-processing block executes matrix permutation orthogonal real-value/QR decomposition, as well as the $y=Q^H r$ calculation. Each PE stage consists of three function blocks: an interference cancelation unit (ICU) that suppresses the inter-antenna interference introduced by the previously detected signals, a node selection unit (NSU) that selects the $L_{i,m}$ best nodes and a PED calculation unit (PCU). The PED calculation unit with orthogonal real value decomposition computes the Euclidean distance between two adjacent tree layers by one PE stage. The number of PE stage is reduced to half of the pipelined detectors by real value decomposition which leads to effective hardware saving. The PEs are divided into PE-A and PE-B, PE-A performs multiple node expansion and PE-B performs single node expansion in remaining three stages. The Min block at the output stage selects branch with smallest Euclidean distance.

5 Implementation Results and Discussion

The designed multi mode MIMO detector is modeled in Verilog Hardware Description Language (Verilog-HDL), and simulated using Modelsim. The proposed detector will support multiple MIMO signal transmission modes namely spatial multiplexing, spatial diversity and space division multiple access. The cost reduction is achieved by the proposed method. The modified architecture reduces arithmetical operations.

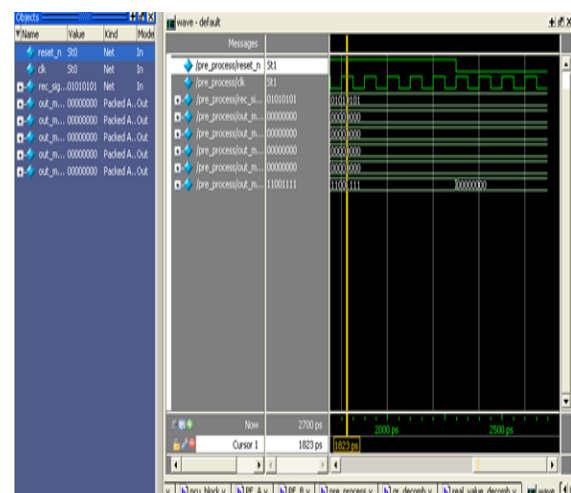

Fig.3 Output Waveform of Pre-processing block

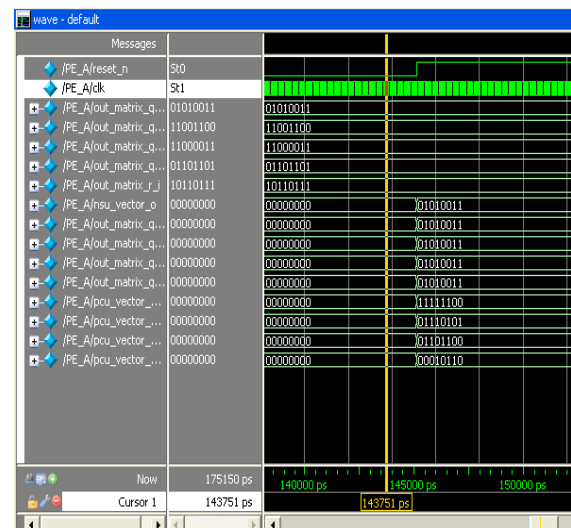

Fig.4 Output Waveform of PE_A

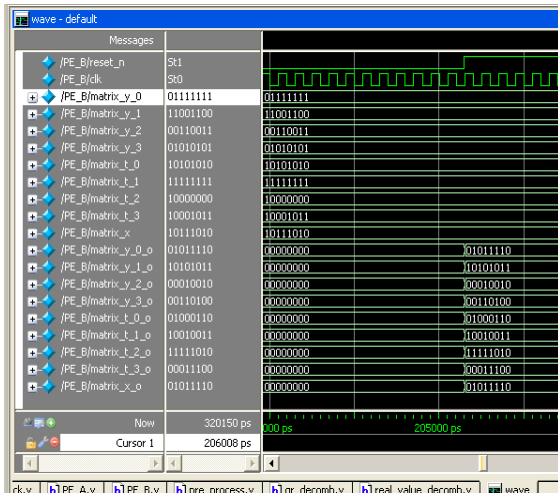

Fig.5 Output Waveform of PE-B

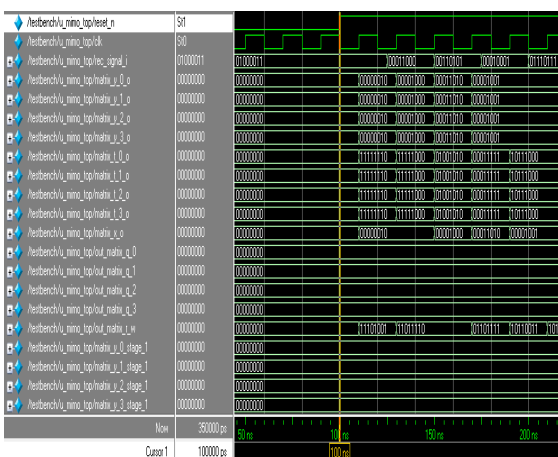

Fig.6 Output Waveform of MIMO detector

6 Conclusion

In this project, an algorithmic design and VLSI implementation of multi mode MIMO detector is proposed. At algorithm level, imbalanced FSD, real value successive interference cancellation and matrix permuted FSD are developed for detecting spatial multiplexing, spatial diversity and space division multiple access signals respectively. The proposed parallel multistage VLSI architecture is developed for high throughput MIMO detector design.

References:

- [1] Liang Liu, Johan Lofgren and Peter Nilsson” Area efficient configurable high throughput-signal detector supporting multiple MIMO modes” *IEEE Trans. Circuits Syst-1*, vol 59, no.9, Sep 2012.
- [2] S. Alamouti, “A simple transmit diversity technique for wireless communications,” *IEEE J. Sel. Areas Commun.*, vol. 16, pp. 1451-1458, Oct 1998.
- [3] J. B. Anderson and S. Mohan, “Sequential coding algorithms: A survey and cost analysis,” *IEEE Trans. Commun.*, vol. COM-32, no. 2, pp. 169-176, Feb 1984.
- [4] A. Burg, M. Borgmann, M. Wenk, M. Zellweger, W. Fichtner, and H. Bolcskei, “VLSI implementation of MIMO detection using the sphere decoding algorithm,” *IEEE J. Solid-State Circuits*, vol. 40, no. 7, pp. 1566-1577, Jul. 2005.
- [5] L. Azzam and E. Ayanoglu, “Reduced complexity sphere decoding for square QAM via a new lattice representation,” in *Proc. IEEE Global Telecommun. Conf.* Nov 2007, pp. 4242-4246
- [6] S. Chen, T. Zhang, and Y. Xin, “Relaxed K-best MIMO signal detector design and VLSI implementation,” *IEEE Trans. Very Large Scale Integr. (VLSI) Syst.*, vol. 15, no. 3, pp. 328-337, Mar. 2007.
- [7] T. H. Im et al., “A new signal detection method for spatially multiplexed MIMO systems and its VLSI implementation,” *IEEE Trans. Circuits Syst. II, Exp. Briefs*, vol.56, no. 5, pp. 399-403, May 2009.
- [8] L. G. Barbero and J. S. Thompson, “Fixing the complexity of the sphere decoder for MIMO detection,” *IEEE Trans. Wireless Commun.*, vol. 7, no. 6, pp. 2131-2142, Jun 2008.
- [9] S.Dragan, L. Angel, and B. P. Constantinou, “Design and experimental validation of MIMO multiuser detection for downlink packet data,” *EURASIP J. Appl. Signal Process.*, vol. 11, pp. 1769-1777, 2005..
- [10] C. J. Huang, C.W. Yu, and H. P. Ma, “A power-efficient configurable low-complexity MIMO detector,” *IEEE Trans.*

- Circuits Syst. I, Reg. Papers*, no. 5, pp. 156-160, Jan. 2009
- [11] S. H. Kang and I. C. Park, "High speed sphere decoding based on vertically incremental computation," in *Proc. IEEE Int. Symp. Circuits Syst. (ISCAS)*, May 2007, pp. 665-668.
- [12] F. Khan, "LTE for 4 G Mobile Broadband: Air Interface Technologies and Performance", *Cambridge, U.K.: Cambridge University Press*, 2009.
- [13] T. H. Kim and I. C. Park, "Small-area and low-energy k-best MIMO detector using relaxed tree expansion and early forwarding," *IEEE Trans. Circuits Syst. I, Reg. Papers*, vol.57, no. 10, pp. 2753-2761, Apr 2010
- [14] J. Lofgren and P. Nilsson, "On MIMO k-best sphere detector architecture complexity reductions ," in *Proc. Int. Conf. Signal Process. Commun. Syst. (ICSPCS)*, Dec. 2008, pp. 1-9.