

Matlab/Simulink Based Dynamic Modeling of Microturbine Generator for Grid and Islanding Modes of Operation

Dr.K.S.SRIKANTH , K.NARESH, Dr.L.V.Narasimha Rao, V.Ramesh

Electrical & Electronics Engineering, KL University Name, India

KL University

INDIA

srikanth.dsd@gmail.com www.kluniversity.in

Abstract: - Distributed generation (DG) is installed by a customer or independent electricity producer that is connected at the distribution system level of the electric grid. Distributed generation installed at sites owned and operated by utility customers, such as microturbine generator (MTG) serving a house or a co-generation facility serving an office. This paper presents the insertion of modeling of microturbine generator in distributed generation for grid connection and islanding operation. The presented paper permits the power flow in both the directions that is in between grid and MTG. The control strategies for grid connection and islanding operation are also presented in this paper.

Key-Words: - Power conditioning, MTG, Distributed generation, Grid, Islanding, Voltage restorer

1 Introduction

Distributed generation is a new trend in the generation of heat and electrical power. Distributed generation, also called on-site generation and dispersed generation. The distributed generation concept permits the "consumer", who is generating heat or electricity for their own needs, to send their surplus electrical power back into the power grid or share excess heat via a distributed heating grid. Distributed generation (DG) refers to power generation at the point of consumption. Generating power on-site, rather than centrally, eliminates the cost, complexity, interdependencies, and inefficiencies associated with transmission and distribution. Distributed generation is based on different types of renewable energy resources like photo voltaic (PV), wind turbine, microturbine generator and fuel cell. In distributed generation microturbine is preferred because of its environmental friendliness with high efficiency. An accurate dynamic model of the microturbine generator is required to analyze transient, stability, harmonics and power quality when connected to the distribution system. A dynamic model of gas turbine was discussed in the previous papers which represent dynamics like speed, acceleration, temperature and fuel controls. A dynamic model of MTG for isolated operation and control of grid connected for split shaft microturbine is considered for this paper. The conversion of power from AC-DC-AC and the modeling of MTG for both grid connected and islanding operation is considered for

the simulation of MTG in Matlab. In this paper two controls are developed. The first one to control the grid interface and the second to control islanding operation of the system. Using matlab/simulink the single shaft MTG is developed in this paper. An extended simulation work is carried in this paper to study the dynamic model of MTG when connected to the distribution networks.

2 Microturbine System Modeling

In this section a model for dynamic analysis of a microturbine generation system is developed. The proposed model describes the dynamics of this device when used as distributed generation source. This model is suitable for transient simulation, analysis and the final model can be used in a distribution network to study the effect of microturbine system on the distribution network stability and the effect of network transients on the microturbine stability. In order to model a microturbine system, four major parts are considered. They are high speed gas turbine, high speed permanent magnet generator, power conditioning unit which itself consist of a rectifier and an inverter and the final part is load connected to microturbine terminal. The proposed model is consisting of the dynamics of each part and their interconnections. The generator generates a very high frequency three phase signal ranging from 1500 to 4000 Hz. The high frequency voltage is first rectified and then inverted to a normal 50 or 60 Hz voltage. The microturbine generate power is in the

range of 30 kW, 60 kW, 65 kW, 200 kW, 600 kW, 800 kW, and 1 MW. Figure 1 shows the components of the microturbine generator.

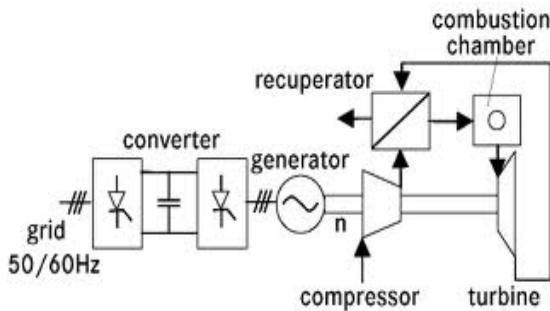

Fig.1. Microturbine generator system (MTGS)

3 Microturbine

Microturbine are small electricity generators that burn gaseous and liquid fuels to create high-speed rotation that turns an electrical generator. The basic components of a microturbine are the compressor, turbine generator, and recuperator is shown in Fig 2. The heart of the microturbine is the compressor-turbine package, which is commonly mounted on a single shaft along with the electric generator. Two bearings support the single shaft. The single moving part of the one-shaft design has the potential for reducing maintenance needs and enhancing overall reliability.

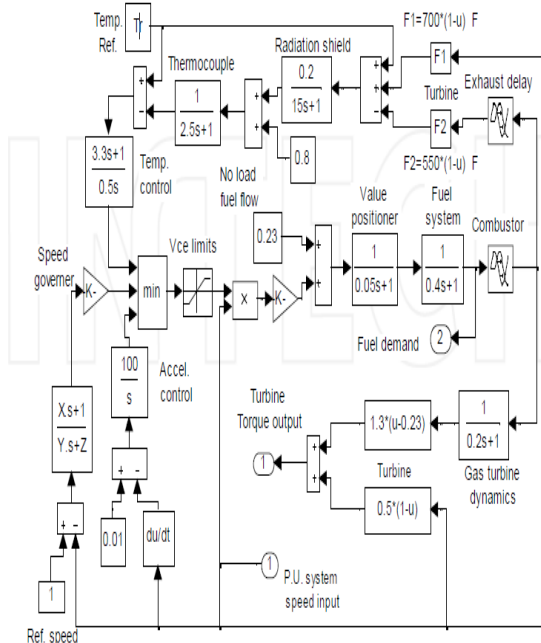

Fig. 2. Simulink model of the microturbine

4 Bearings

Microturbines operate on either oil-lubricated or air bearings which support the shaft(s). Oil-lubricated bearings are mechanical bearings which are in three main forms - high-speed metal roller, floating sleeve, and ceramic surface. The latter typically offer the most attractive benefits in terms of life, operating temperature, and lubricant flow. While they are a well-established technology, they require an oil pump, oil filtering system, and liquid cooling that add to microturbine cost and maintenance. In addition, the exhaust from machines featuring oil-lubricated bearings may not be useable for direct space heating in cogeneration configurations due to the potential for contamination. Since the oil never comes in direct contact with hot combustion products, as is the case in small reciprocating engines.

5 Power Electronics

The single-shaft microturbine feature digital power controllers to convert the high frequency AC power produced by the generator into usable electricity. The high frequency AC is rectified to DC, inverted back to 60 or 50 Hz AC, and then filtered to reduce harmonic distortion. This is a critical component in the single-shaft microturbine design and represents significant design challenges, specifically in matching turbine output to the required load. To allow for transients and voltage spikes, power electronics designs are generally able to handle seven times the nominal voltage. Most of the microturbine power electronics are generating three-phase electricity.

6 Recuperator

Microturbines are more complex than conventional simple-cycle gas turbine, as the addition of the recuperator both reduces fuel consumption (thereby substantially increasing efficiency) and introduces additional internal pressure losses that moderately lower efficiency and power. As the recuperator has four connections -- to the compressor discharge, the expansion turbine discharge, the combustor inlet, and the system exhaust -- it becomes a challenge to the microturbine product designer to make all of the connections in a manner that minimizes pressure loss, keeps manufacturing cost low, and entails the least compromise of system reliability.

Microturbine performance, in terms of both efficiency and specific power, is highly sensitive to small variations in component performance and

internal losses. This is because the high efficiency recuperated cycle processes a much larger amount of air and combustion products flow per kW of net power delivered than is the case for high-pressure ratio simple-cycle machines. When the net output is the small difference between two large numbers (the compressor and expansion turbine work per unit of mass flow), small losses in component efficiency, internal pressure losses and recuperator effectiveness have large impacts on net efficiency and net power per unit of mass flow.

7 Permanent Magnet Synchronous Machine

The microturbine generates electrical power via a high speed PMSG, directly driven by the turbine rotor shaft. In this work, the model adopted for the generator is a 2 pole permanent magnet synchronous generator (PMSG) with non-salient rotor. At 1.6 kHz (61,000 rpm), the rated output power generated by the machine is 60kW and its terminal line to line voltage is 550V. The Permanent Magnet Synchronous Machine block operates in either generator or motor mode. The mode of operation is dictated by the sign of the mechanical torque (positive for motor mode, negative for generator mode). The electrical and mechanical parts of the machine are each represented by a second-order state-space model. The sinusoidal model assumes that the flux established by the permanent magnets in the stator is sinusoidal, which implies that the electromotive forces are sinusoidal. The trapezoidal model assumes that the winding distribution and flux established by the permanent magnets produce three trapezoidal back EMF waveforms. The below equations are expressed in the rotor reference frame (qd frame). All quantities in the rotor reference frame are referred to the stator.

$$\frac{d}{dt}i_d = \frac{1}{L_d}v_d - \frac{R}{L_d}i_d + \frac{L_q}{L_d}p\omega_r i_q \tag{1}$$

$$\frac{d}{dt}i_q = \frac{1}{L_q}v_q - \frac{R}{L_q}i_q - \frac{L_d}{L_q}p\omega_r i_d - \frac{\lambda p\omega_r}{L_q} \tag{2}$$

$$T_e = 1.5 p [\lambda i_q + (L_d - L_q) i_d i_q] \tag{3}$$

8 Line Side Converter Control

The supply-side converter is to keep the DC-link voltage constant, irrespective of the magnitude and direction of the rotor power. A vector control approach is used here, with the reference frame

oriented along the stator (or supply) voltage vector position

9 Grid Connected Mode

The PQ control strategy with DC link voltage control is employed for grid connected operation of MTG system. In this scheme the power injected to the grid is regulated by controlling the injected current. The control structure for grid-connected operation mode of MTG system is shown in Figure 3. The standard PI-controllers are used to regulate the currents in the dq synchronous frame in the inner control loops as they have satisfactory behavior in regulating DC variables, as well as filtering and controlling can be easily achieved. Another PI controller is used in the outer loop to regulate the capacitor voltage in accordance with the current injected in to the grid. Its output is the reference for the active current PI controller. In order to obtain only a transfer of active power, the iq current reference is set to zero. And also to have independent control of the current components id and iq the decoupling voltage components are added to the output of current PI controllers.

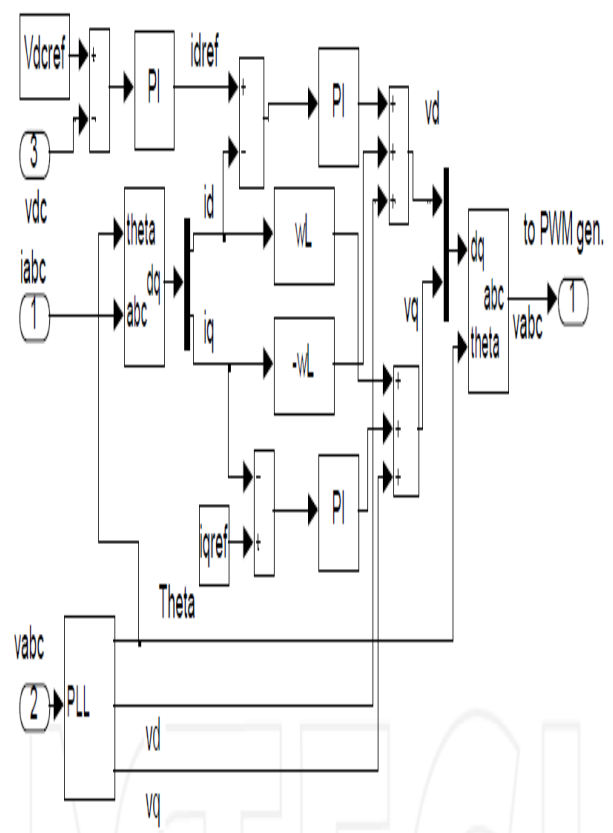

Fig.3. Grid side converter controller

Converter voltages can be given as:

$$v_a(t) = \sqrt{\frac{2}{3}} V \cos(\omega t), \quad v_b(t) = \sqrt{\frac{2}{3}} V \cos(\omega t - \frac{2\pi}{3}), \quad v_c(t) = \sqrt{\frac{2}{3}} V \cos(\omega t - \frac{4\pi}{3}) \quad (4)$$

$$u_d = R i_d + L_d \frac{di_d}{dt} + v_d - \omega L i_q$$

$$u_q = R i_q + L_q \frac{di_q}{dt} + \omega L_d i_d + v_q \quad (5)$$

Where, the dq currents are controlled by means of the right choice of the dq converter side voltages. Two PI regulators are command a PWM modulator to generate the voltage that should control the current.

10 Islanding Mode

The islanding mode operation of single shaft MTG system requires a control different from that of grid connected mode. In this mode, the system has already been disconnected from the utility. Therefore the voltage and frequency is no longer regulated by it. Thus the output voltages are to be controlled in terms of amplitude and frequency which leads to control of the reactive and active power flow.

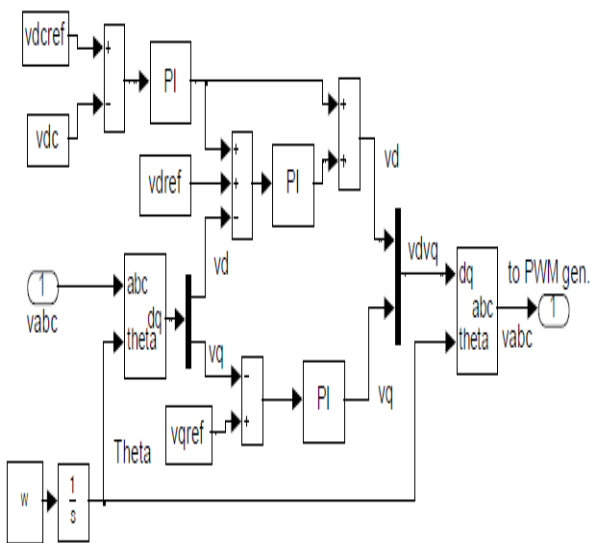

Fig. 4. Control structure for islanding mode operation

This is done by controlling the amplitude and frequency of the modulating input-signal to the PWM inverter. The control structure for islanding mode is depicted in Fig. 4. It consists of output voltage and DC link voltage PI controllers. The output voltage controllers control the output voltage with a minimal influence from nature of the load currents or load transients. A standard PI controller operating in the synchronously rotating coordinate system where, v_q is kept to zero is used. The DC voltage PI controller controls the DC voltage level based on the reference. For fast response the output of the DC voltage controller is feed forwarded to the voltage controller output. The DC link voltage controller acts only when the DC link voltage is below the reference and it lowers the voltage reference of the main voltage controller in order to avoid inverter saturation. The frequency control is done by integrating the constant reference frequency ω and using it for coordinate transfer of the voltage components from abc to dq and vice versa.

11 Simulation And Results

Figure 5 shows the simulation model implemented in the Sim Power Systems of the MATLAB to study the performance of the MTG system operation in grid connected mode. The utility network, to which the MTG system is connected, is represented by a 3 phase sinusoidal source with its impedance. The series RL filter is used at the grid side of the MTG system.

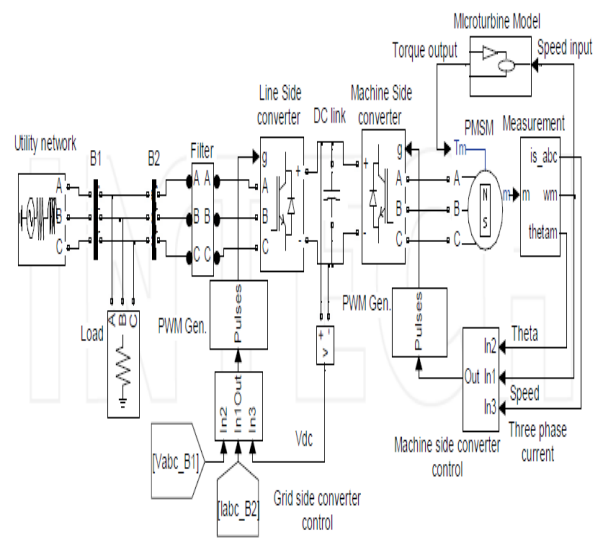

Fig. 5. Matlab/ Sim Power Systems implementation of MTG system connected to grid

The microturbine generation system takes per unit speed of the PMSM as input. The torque output of the microturbine is given as an input mechanical torque (T_m) to the PMSM. The direction of the torque T_m , is positive during motoring mode and made negative during generating mode of the PMSM. The machine side converter controller takes the rotor angle speed and 3 phase stator current signals of the PMSM as inputs. In all the presented cases the voltage across the capacitor is zero, at the starting of simulation. During the start up, the PMSM operates as a motor to bring the turbine to a speed of 30,000 rpm. In this case power flows from the grid to MTG system

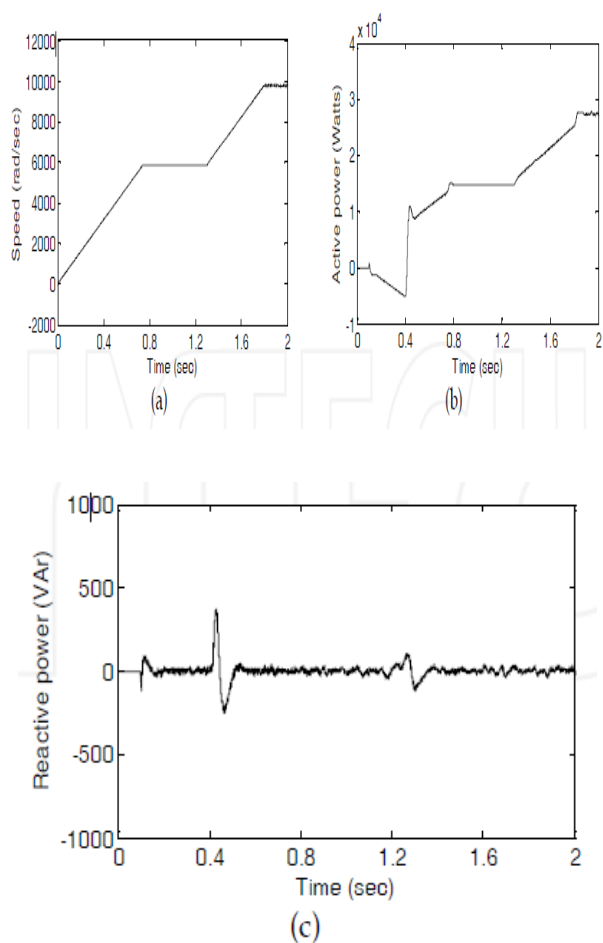

Fig. 6. Motoring and generating operation of PMSM (a) speed variation of PMSM (b) active power variation at the grid side of the MTG system (c) reactive power variations at the grid side of the MTG system

Figure 6 shows that the microturbine reaches the set value of speed in 0.4 sec. At this speed, the MTG system absorbs power of 5.4 kW as shown in Fig. 6 (b). The PMSM terminal voltage reaches 192 V at a

frequency of 500 Hz at this speed. To ensure this operating condition at an unity displacement factor, the pre-calculated reference speed and direct current component i_d are set to 3142 rad/s and -5.36 A. The speed regulator provides the reference for the i_q current component. At $t=0.4$ sec, the sign of the PMSM input torque is changed to operate it in generating mode. The power starts flowing from the MTG system to grid as shown in Fig. 6 (b).

At $t=0.4$ sec, the reference speed and i_d current are set to the pre-calculated values of 5849 rad/sec and -15.89 amps in order to generate power of 14 kW. In order to study the performance of the MTG system model for the change in power, the reference values of speed and i_d current component are again changed at $t=1.3$ sec to generate the rated power of 28 kW. When PMSM generates 28 kW, its line to line voltage and fundamental RMS output current reach the value of 480 V and 33.84 A respectively. Fig. 6 (c) shows that the reactive power injected to the grid during the simulation period is zero.

12 Conclusion

Figure 7 (a) shows the variation of electromagnetic torque of the PMSM. In this it can be observed that, the change in the operation mode of PMSM in simulation is instantaneous. But this may not be the same in practical because of the inertia of the machine. Figure 7 (b) shows the nature of the stator current waveform of the PMSM. It can be observed from Fig. 7 (c) that the DC link voltage is regulated to 760 V by the grid side converter.

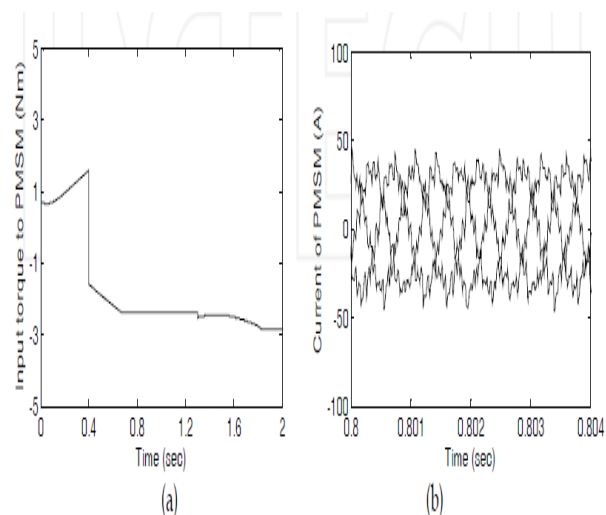

Figures 7 (d) and (e) show the variation of i_d component of the injected grid current and the voltage across the terminals of the load. There is a small decrease in the voltage for $t < 0.4$ sec, as

shown in Fig. 7(e). This is due to the increasing power drawn by the MTG system during motoring mode operation as shown in Fig. 6 (b). In motoring mode both MTG system and load draw power from the grid. The total harmonic distortion (THD) of the voltage is about 2.3% during the entire simulation time as shown in Fig. 7(f).

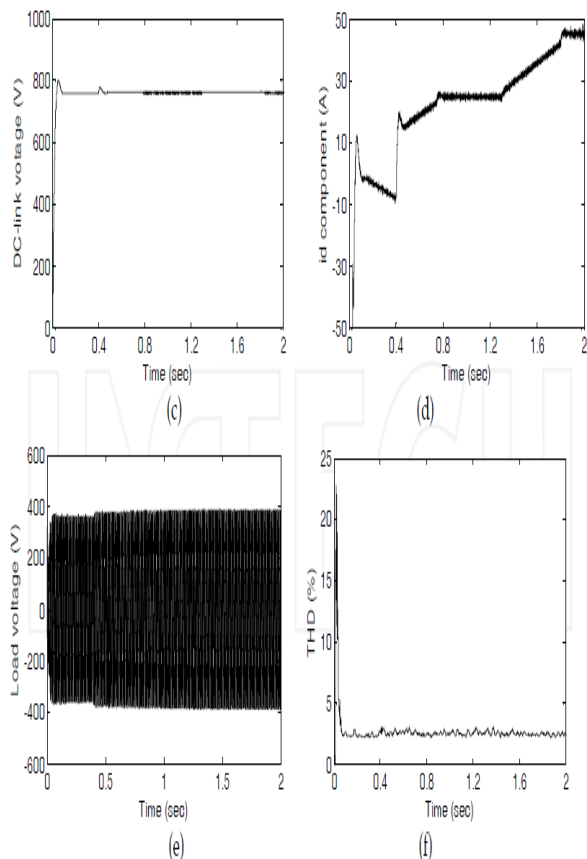

Fig. 7. (a) Electromagnetic torque variations of the PMSM (b) Detailed variations of the stator current of PMSM (c) DC link voltage variation (d) i_d component of the injected grid current (e) Line to line voltage at the load terminals (f) %THD variation at the load terminals.

References

- [1] R. Esmaili, D. Das, D.A. Klapp, O. Dernici, and D.K. Nichols, "A novel power conversion system for distributed energy resources," *IEEEProc. PESGM 2006*, pp. 1-6.
- [2] M. Brenna, E. Tironi, and G. Ubezio, "Proposal of a local dc distribution network with distributed energy resources," *Proc. Int. Conf. on Harmonics and Quality of Power*, Sept 2004, pp. 397-402.

- [3] Y. Zhu, and K. Tomsovic, "Optimal distribution power flow for systems with distributed energy resources," *Electrical Power and Energy Systems*, Vol. 29, 2007, pp. 260-267,
- [4] N. Hatziaargyriou, G. Kariniotakis, N. Jenkins, J. Pecas Lopes, J.Oyazabal, F. Kanellos, X. Pivert Le, N. Jayawarna, N. Gil, C. Moriera, and Z. Larrabe, "Modelling of micro sources for security studies," *Proc. CIGRE Session*, Paris, France,., Aug Sept 2004, (pages) 7
- [5] J.C. Ho, K.J. Chua, and S.K. Chou, "Performance study of a microturbine system for cogeneration application," *Renewable Energy*, 2004, vol. 29pp. 1121-1133.
- [6] T. Senjyu, H.Takara, K.Uezato, T. Funabashi, T. Ito, "Load-following control for dispersed generators using a PI controller", *Electrical Eng. In Japan*, Vol. 145, No 2, July 2003 pp. 58-66.
- [7] A.K.Saha, S.Chowdhury, S.P.Chowdhury and P.A.Crossley, Microturbine Based Distributed Generator In Smart Grid Application, *IEEE20th International Conference and Exhibition on Electricity Distribution. Smart Grids for Distribution*, CIRD-2009, pp 1-6.
- [8] Samuele Grillo, Stefano Massucco, Andrea Morini, Andrea Pitto and Federico Silvestro, Microturbine Control Modelling to Investigate the Effects of Distributed Generation in Electric Energy Networks, *IEEE Systems Journal*, 2010, 4, pp 303-311.
- [9] Chi-Hshiang Lin, Dynamic Simulations for Operation Mode Transfer of a Micro-Turbine Generator, *Journal of Technology*, 2008, pp 2311-20
- [10] D. N. Gaonkar, R .N. Patel, and G. N. Pillai, Dynamic Model of Microturbine Generation System for Grid Connected/Islanding Operation, *IEEE International Conference on Industrial Technology*, 2006, pp. 305-310.